



VM Series

CLOSE-COUPLED THREADED VERTICAL MULTISTAGE CENTRIFUGAL ELECTRIC PUMPS
EQUIPPED WITH IE2, IE3 MOTORS (REG. (EU) 2019/1781)

ErP 2009/125/EC

Directive 2009/125/EC of the European Union

The **Directive 2005/32/EC** on energy-using products (**EuP**) and the subsequent **Directive 2009/125/EC** on energy-related products (**ErP**) established the ecodesign requirements for products to reduce their energy consumption and consequently their environmental impact.

These requirements apply to products placed and used in the European Economic Area (European Union plus Iceland, Liechtenstein and Norway) as a stand-alone unit or as integrated parts in other products.

The following tables show the Regulations that define the requirements applicable to Lowara products.

- Some types of **pump**, used for pumping clean water:

| Regulations | From | Target |
|---|----------------|------------------|
| (EU) N. 547/2012 and subsequent updates | 1 January 2015 | MEI ≥ 0,4 |

- **Circulators** with a rated hydraulic output power of between 1 and 2500 W, designed for use in heating systems or in secondary circuits of cooling distribution systems:

| Regulations | From | Target |
|---|---------------|-------------------|
| (EC) N. 641/2009 and subsequent updates | 1 August 2015 | EEL < 0,23 |

- **Three-phase motors** with frequency 50 or 60 or 50/60 Hz and voltages between 50 and 1000 V (S1 and D.O.L.):

| Regulations | From | Target |
|---------------------------------------|-------------|---|
| (EU) 2019/1781 and subsequent updates | 1 July 2023 | IE2 : motors with a rated output ≥ 0,12 and < 0,749 kW IE3 : motors with a rated output ≥ 0,75 and < 74,9 kW IE4 : motors with a rated output ≥ 75 and < 200 kW IE3 : motors with a rated output ≥ 201 and < 1000 kW |

- **Single-phase motors** with frequency 50 or 60 or 50/60 Hz and voltages between 50 and 1000 V (S1 and D.O.L.):

| Regulations | From | Target |
|-----------------------------|-------------|---|
| (EU) 2019/1781 and 2021/341 | 1 July 2023 | IE2 : motors with a rated output ≥ 0,12 kW |

- **Variable speed drives** with three-phase input and rated output power from 0,12 kW up to 1000 kW, rated for operating with motor included in the same regulations:

| Regulations | From | Target |
|-----------------------------|-------------|------------|
| (EU) 2019/1781 and 2021/341 | 1 July 2021 | IE2 |

CONTENTS

| | |
|---|-----------|
| GENERAL INTRODUCTION | 5 |
| APPLICATIONS, BENEFITS – BUILDING SERVICES..... | 6 |
| GENERAL CHARACTERISTICS / IDENTIFICATION CODE | 7 |
| ELECTRIC PUMP RATING PLATE / MECHANICAL SEAL | 8 |
| 1, 3, 5, 10 VM..P SERIES ELECTRIC PUMP CROSS SECTION AND MAIN COMPONENTS..... | 9 |
| MOTORS (ErP 2009/125/EC) | 10 |
| PUMPS (ErP 2009/125/EC)..... | 13 |
| HYDRAULIC PERFORMANCE RANGE AT 50 Hz, 2 POLES..... | 14 |
| HYDRAULIC PERFORMANCE TABLE AT 50 Hz, 2 POLES..... | 15 |
| DIMENSIONS AND WEIGHTS, OPERATING CHARACTERISTICS AT 50 HZ, 2 POLES..... | 16 |
| VME VERSION WITH DRIVE AND PERMANENT MAGNET MOTOR (e-SM DRIVE)..... | 25 |
| REPORTS AND DECLARATIONS | 53 |
| TECHNICAL APPENDIX..... | 55 |

VM SERIES

GENERAL INTRODUCTION

Our customers are central to our business.

Many years of collaboration with them across the different markets and all over the world has taught us that the Building Services market requires specific pump design to meet the challenge of the energy saving and market competitiveness, also through performances and reliability. Therefore Lowara has developed a new range of single piece vertical multistage pumps, the VM, to give an appropriate and dedicated solution to special applications and installations in the residential and commercial building services market.

Pump design

The VM is a non-self-priming vertical multistage, high pressure centrifugal pump, with threaded inlet and outlet manifolds. The pumps are close-coupled design and are equipped with non-standard Lowara motors. The VM is equipped with mechanical seal. The VM are highly modular pumps that are fitted with an innovative hydraulic design that secures high efficiency performances and an increased Mean Time Between Failure.

The VM is available in four different sizes; the design is made of a cast iron pump body coupled to an external stainless steel (EN 1.4301/ AISI 304) TIG welded sleeve with the mean of stainless steel tie rods screwed in the aluminum motor flange. The impellers are made in technopolymer.

Motor

The VM are equipped with Lowara designed and manufactured surface motors in accordance with EN standards. The VM series can be equipped as well with Lowara variable speed drivers.

Range declination

The VM series are available as:

- Single pump.
- Variable speed system.

SPECIFICATIONS

PUMP

- Flow rate: up to 14 m³/h.
- Head: up to 98 m.
- Ambient temperature:
 - Single-phase motor versions from -15°C to +45°C.
 - Three-phase motor versions from -15°C to +50°C.
- Temperature of the pumped liquid: +90°C for uses as EN 60335-2-41.
- Maximum operating pressure: 10 bar (PN 10).
- Connections: Rp threaded for both suction and discharge manifold.
- Hydraulic performances compliant with ISO 9906:2012 - Grade 3B.



MARKET SECTORS

BUILDING SERVICES.

APPLICATIONS

- Pressure boosting and water supply systems.
- Small to medium irrigation systems.
- Liquid handling systems.

MOTOR

- Electric short-circuit squirrel-cage motor, enclosed construction, air-cooled (TEFC).
- IP 55 protection degree.
- Insulation class 155 (F).
- Performances according to EN 60034-1.
- Standard voltage:
 - Single-phase: 220-240V, 50 Hz.
 - Three-phase: 220-240/380-415V, 50 Hz up to 3 kW.

The VM pumps are available in a version suitable for contact with drinking water.

VM SERIES APPLICATIONS, BENEFITS – BUILDING SERVICES

The VM series have been designed to cover a wide range of applications in the residential and small commercial building services from water supply to pressure boosting.

Applications

The VM series could be installed both in single private own house and in small/medium residential buildings. The VM series will be as well your preferred choice for water supply and pressure boosting in small block offices and shops. The VM series could be finally installed as well for small/medium irrigation installation.

Benefits

Ease of installation: thanks to the limited dimensions due to the close-coupled vertical design, the VM is easy to handle and install.

Payback: Installing the VM series guarantee a very short payback period thanks to the high performance and to the competitive market positioning.

Reliability: The VM series secures as well reliable operations over time thanks to its robust and innovative design, heritage of the e-HM. This could be increased with the installation of the e-SM Drive: variable speed operation reduces mechanical stress on the pump components and water hammering during stopping.

Comfort: The VM series guarantee as well an increased user comfort thanks to very silent operation. The combination of the VM series with the e-SM Drive will secure constant pressures at any points of water in your building and constant temperatures even when other taps are opened!



Features

- Compact design with best-in class performances.
- Wide range of performances with 4 sizes and flow up to 14m³/h.
- Nominal pressure up to 10 bars.
- Robust and silent design due the sleeve configuration.
- IE2/IE3 Lowara manufactured motors: high performances and silent operations.
- "Essential O-ring design" that highly reduces the sealing weaknesses (Only 2 OR in the sleeve design).

**VM SERIES
ELECTRIC PUMP RATING PLATE**

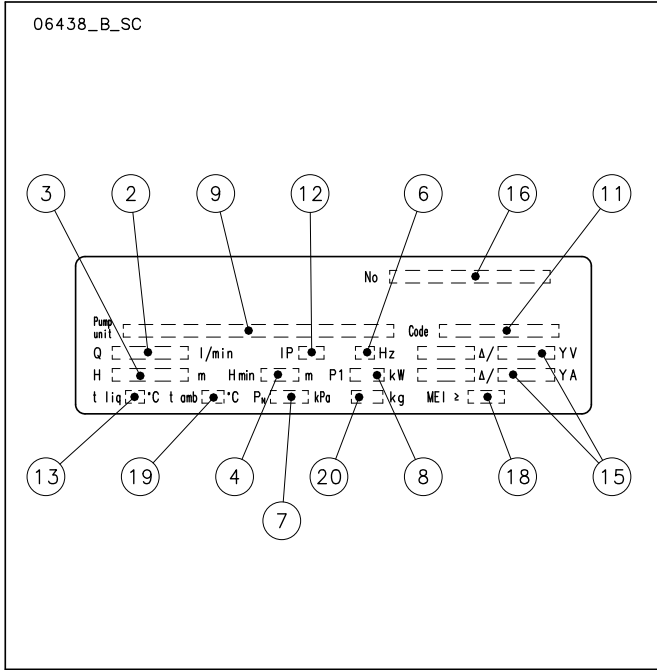

LEGEND

- 2 - Capacity range
- 3 - Head range
- 4 - Minimum head (EN 60335-2-41)
- 6 - Frequency
- 7 - Maximum operating pressure
- 8 - Electric pump unit absorbed power
- 9 - Pump / electric pump unit type
- 11 - Electric pump unit / pump part number
- 12 - Protection degree
- 13 - Maximum operating liquid temperature (uses as EN 60335-2-41)
- 15 - Rated voltage range
- 16 - Serial number (date + progressive number)
- 18 - MEI index (Regulation (EU) n. 547/2012)
- 19 - Maximum operating ambient temperature
- 20 - Electric pump weight

MECHANICAL SEAL

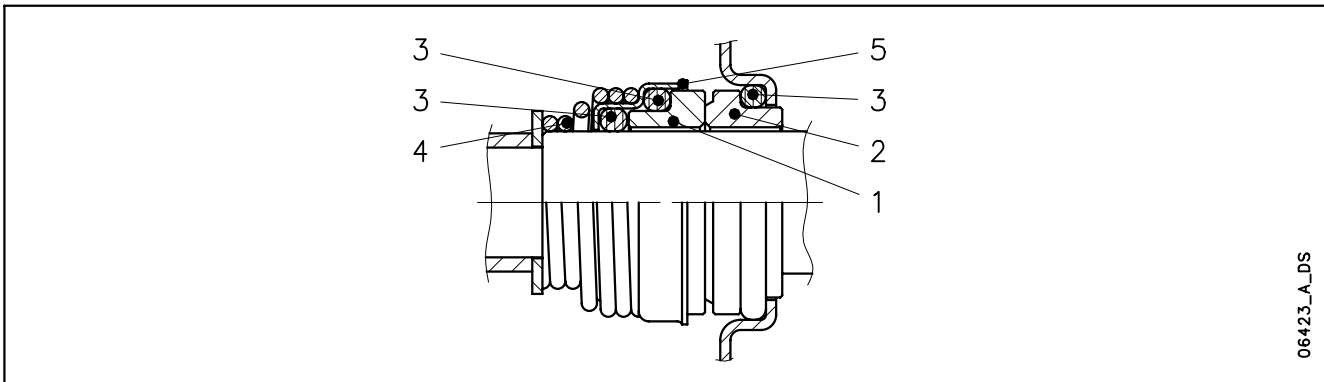

06423_A_DS

LIST OF MATERIALS

| POSITION 1 - 2 | POSITION 3 | POSITION 4 - 5 |
|--|----------------|----------------|
| V : Aluminium oxide (Ceramic) B3 : Graphite | E2 : EPDM-WRAS | G : AISI 316 |

1-10vm_ten-mec-en_b_tm

TYPE OF SEAL

| TYPE | POSITION | | | | | *TEMPERATURE (°C) | OPERATING PRESSURE |
|-----------------------------------|--------------------|----------------------|-----------------|--------------|-----------------------|----------------------|-----------------------|
| | 1 ROTATING PART | 2 STATIONARY PART | 3 ELASTOMERS | 4 SPRINGS | 5 OTHER COMPONENTS | | |
| STANDARD MECHANICAL SEAL | | | | | | | |
| VB ₃ E ₂ GG | V | B ₃ | E ₂ | G | G | -30 + 90 | PN10 |

1-10vm_tipi-ten-mec-en_b_tc

1, 3, 5, 10 VM..P SERIES

ELECTRIC PUMP CROSS SECTION AND MAIN COMPONENTS

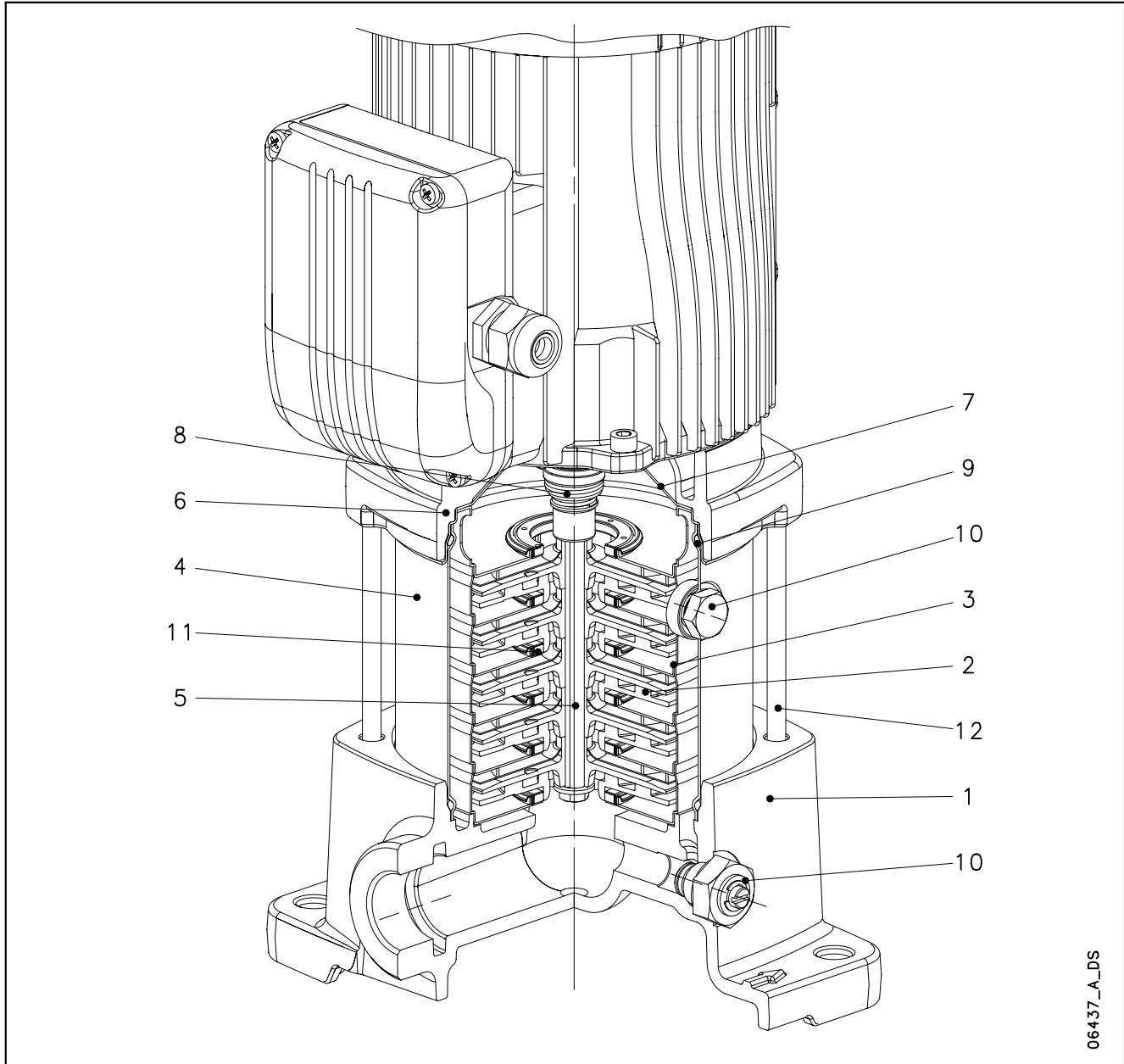

06437_A_DS

TABLE OF MATERIALS

| REF. N. | NAME | MATERIAL | REFERENCE STANDARDS | |
|---------|--------------------|-------------------------|-------------------------------------|---------------|
| | | | EUROPE | USA |
| 1 | Pump body | Cast iron | EN 1561-GJL-200 (JL1030) | ASTM Class 25 |
| 2 | Impeller | Technopolymer | | |
| 3 | Diffuser | Stainless steel | EN 10088-1-X5CrNi18-10 (1.4301) | AISI 304 |
| 4 | Outer sleeve | Stainless steel | EN 10088-1-X5CrNi18-10 (1.4301) | AISI 304 |
| 5 | Shaft | Stainless steel | EN 10088-1-X5CrNi18-10 (1.4301) | AISI 304 |
| 6 | Adapter | Aluminium | EN 1706-AC-AISI11Cu2 (Fe) (AC46100) | - |
| 7 | Seal housing | Stainless steel | EN 10088-1-X5CrNi18-10 (1.4301) | AISI 304 |
| 8 | Mechanical seal | Ceramic / Carbon / EPDM | | |
| 9 | Elastomers | EPDM | | |
| 10 | Fill / drain plugs | Stainless steel | EN 10088-1-X5CrNi18-10 (1.4301) | AISI 304 |
| 11 | Wear ring | Technopolymer (PPS) | | |
| 12 | Tie rods | Stainless steel | EN 10088-1-X17CrNi16-2 (1.4057) | AISI 431 |

1-3-5-10vm-p-en_b_tm

VM SERIES MOTORS (ErP 2009/125/EC)

- Short-circuit squirrel-cage motor, enclosed construction with external ventilation (TEFC).
- **IP 55** protection degree.
- Insulation class **155 (F)**.
- Electrical performances according to EN 60034-1.
- Supplied **single-phase** surface motors with **IE2** efficiency level.
- Supplied **three-phase** surface motors with **IE2** efficiency level for power <0,75 kW, **IE3** efficiency level for power ≥ 0,75 kW as standard according to EN 60034-30:2009 and EN 60034-30-1:2014.
- Cable gland with metric according to EN 50262.
- **Single-phase** version:
0,55 to 1,5 kW (2-pole)
220-240 V 50 Hz
Built-in automatic reset overload protection
Maximum ambient temperature: 45 °C.
- **Three-phase** version:
0,30 to 5,5 kW (2-pole)
220-240/380-415 V 50 Hz for power up to 3 kW.
Overload protection to be provided by the user.
Maximum ambient temperature: 50 °C

From 1 July 2023 in accordance with the **Regulations (EU) 2019/1781 and 2021/341**, the **three-phase** 50 Hz, 60 Hz or 50/60 Hz **surface motors** with **power outputs ranging from 0,12 to 0,749 kW** must have a minimum level **IE2** efficiency; the ones with power outputs ranging **from 0,75 to 74,9 kW** must have a minimum level of **IE3** efficiency. The **single-phase surface motors** with **power outputs ranging from 0,12 kW** must have a minimum level **IE2** efficiency.

The following tables also contain the mandatory information pursuant to Annex I, section 2, of the aforementioned Regulations.

SINGLE-PHASE MOTORS AT 50 Hz, 2-POLE

| P _N kW | MOTOR TYPE | IEC SIZE | Construction Design | INPUT CURRENT I _n (A) 220-240 V | CAPACITOR | | DATA FOR 230 V 50 Hz VOLTAGE | | | | | | | OPERATING CONDITIONS * | | |
|----------------------|-------------------|----------|---------------------|--|-----------|-----|------------------------------|---------------------------------|------|------|----------------------|--------------------------------|--------------------------------|------------------------|-------------------------|------|
| | | | | | μF | V | min ⁻¹ | I _s / I _n | η % | cosφ | T _n Nm | T _s /T _n | T _m /T _n | Altitude asl m | T. amb min/max °C | ATEX |
| 0,55 | SM71HM../1055 E2 | 71 | SPECIAL | 3,33-3,19 | 16 | 450 | 2810 | 4,16 | 74,1 | 0,99 | 1,87 | 0,69 | 2,13 | VI 1000 | -15/45 | No |
| 0,75 | SM80HM../1075 E2 | 80 | | 4,38-4,27 | 25 | 450 | 2865 | 5,11 | 77,4 | 0,97 | 2,50 | 0,40 | 2,26 | | | |
| 1,1 | SM80HM../1115 E2 | 80 | | 6,26-5,93 | 30 | 450 | 2860 | 4,78 | 79,6 | 0,98 | 3,67 | 0,50 | 2,14 | | | |
| 1,5 | PLM90HM../1155 E2 | 90 | | 8,41-7,87 | 50 | 450 | 2890 | 6,71 | 81,3 | 0,97 | 4,95 | 0,59 | 2,78 | | | |

** Operating conditions related only to the motor. For the electric pump refer to the IOM.

1-22hm-motm_2p50-en_c_te

VM SERIES
THREE-PHASE MOTORS AT 50 Hz, 2-POLE

| P _N kW | Fabbricante | | Grandezza IEC | Forma costruttiva | N. poli | f _N Hz | Dati relativi alla tensione di 400 V / 50 Hz | | | | |
|----------------------|--|--|------------------|----------------------|------------|----------------------|--|---------------------------------|----------------------|--------------------------------|--------------------------------|
| | Xylem Service Italia srl Reg. No. 07520560967 Montecchio Maggiore Vicenza - Italia | | | | | | cosφ | I _s / I _N | T _N Nm | T _s /T _N | T _m /T _N |
| | Modello | | | | | | | | | | |
| 0,30 | SM63HM../303 | | 63 | SPECIALE | 2 | 50 | 0,63 | 4,20 | 1,04 | 4,18 | 4,12 |
| 0,40 | SM63HM../304 | | 63 | | | | 0,64 | 4,35 | 1,37 | 4,14 | 4,10 |
| 0,50 | SM63HM../305 | | 63 | | | | 0,69 | 4,72 | 1,75 | 4,08 | 4,00 |
| 0,55 | SM71HM../305 | | 71 | | | | 0,71 | 6,25 | 1,84 | 3,96 | 3,97 |
| 0,75 | SM80HM../307 E3 | | 80 | | | | 0,78 | 7,38 | 2,48 | 3,57 | 3,75 |
| 1,1 | SM80HM../311 E3 | | 80 | | | | 0,79 | 8,31 | 3,63 | 3,95 | 3,95 |
| 1,5 | SM80HM../315 E3 | | 80 | | | | 0,80 | 8,80 | 4,96 | 4,31 | 4,10 |
| 2,2 | PLM90HM../322 E3 | | 90 | | | | 0,80 | 8,77 | 7,28 | 3,72 | 3,70 |
| 3 | PLM90HM../330 E3 | | 90 | | | | 0,79 | 7,81 | 9,93 | 4,26 | 3,94 |

| P _N kW | Tensione U _N V | | | | | | | | | | | n _N min ⁻¹ | Condizioni operative ** | | |
|----------------------|------------------------------|-------|-------|-------|-------|-------|-------|-------|-------|-------|-------|-------------------------------------|---------------------------|-------------------------|------|
| | Δ | | | Y | | | Δ | | | Y | | | Altitudine s.l.m. m | T. amb min/max °C | ATEX |
| | 220 V | 230 V | 240 V | 380 V | 400 V | 415 V | 380 V | 400 V | 415 V | 660 V | 690 V | | | | |
| | I _N (A) | | | | | | | | | | | | | | |
| 0,30 | 1,66 | 1,82 | 1,96 | 0,96 | 1,05 | 1,13 | - | - | - | - | - | 2715 ÷ 2775 | ≤ 1000 | -15 / 50 | No |
| 0,40 | 2,03 | 2,18 | 2,32 | 1,17 | 1,26 | 1,34 | - | - | - | - | - | 2745 ÷ 2800 | | | |
| 0,50 | 2,42 | 2,51 | 2,65 | 1,40 | 1,45 | 1,53 | - | - | - | - | - | 2690 ÷ 2765 | | | |
| 0,55 | 2,46 | 2,49 | 2,56 | 1,42 | 1,44 | 1,48 | - | - | - | - | - | 2835 ÷ 2865 | | | |
| 0,75 | 2,96 | 2,94 | 2,96 | 1,71 | 1,70 | 1,71 | 1,70 | 1,69 | 1,70 | 0,98 | 0,98 | 2875 ÷ 2895 | | | |
| 1,1 | 4,19 | 4,14 | 4,16 | 2,42 | 2,39 | 2,40 | 2,41 | 2,38 | 2,38 | 1,39 | 1,37 | 2870 ÷ 2900 | | | |
| 1,5 | 5,56 | 5,49 | 5,51 | 3,21 | 3,17 | 3,18 | 3,21 | 3,18 | 3,19 | 1,85 | 1,84 | 2870 ÷ 2895 | | | |
| 2,2 | 7,97 | 7,90 | 7,98 | 4,60 | 4,56 | 4,61 | 4,57 | 4,54 | 4,57 | 2,64 | 2,62 | 2880 ÷ 2900 | | | |
| 3 | 11,0 | 11,0 | 11,2 | 6,35 | 6,33 | 6,44 | 6,29 | 6,27 | 6,34 | 3,63 | 3,62 | 2865 ÷ 2895 | | | |

| P _N kW | Rendimento η _N % | | | | | | | | | | | | | | | | | | IE |
|----------------------|--------------------------------|------|------|--------------------|------|------|--------------------|------|------|--------------------|------|------|--------------------|------|------|---------|------|------|----|
| | Δ 220 V Y 380 V | | | Δ 230 V Y 400 V | | | Δ 240 V Y 415 V | | | Δ 380 V Y 660 V | | | Δ 400 V Y 690 V | | | Δ 415 V | | | |
| | 4/4 | 3/4 | 2/4 | 4/4 | 3/4 | 2/4 | 4/4 | 3/4 | 2/4 | 4/4 | 3/4 | 2/4 | 4/4 | 3/4 | 2/4 | 4/4 | 3/4 | 2/4 | |
| 0,30 | 67,1 | 69,6 | 65 | 67,1 | 66,5 | 60,2 | 67,1 | 63,3 | 55,7 | - | - | - | - | - | - | - | - | - | 2 |
| 0,40 | 70,4 | 73,2 | 68,9 | 70,4 | 70,3 | 64,5 | 70,4 | 67,2 | 60,2 | - | - | - | - | - | - | - | - | - | |
| 0,50 | 73 | 76,1 | 73,4 | 73 | 73,8 | 69,6 | 73 | 71,3 | 65,7 | - | - | - | - | - | - | - | - | - | |
| 0,55 | 74,1 | 74,2 | 70,4 | 74,1 | 73,6 | 68,8 | 74,1 | 72,7 | 67,1 | - | - | - | - | - | - | - | - | - | |
| 0,75 | 82,5 | 83,1 | 81,3 | 82,8 | 82,7 | 80,1 | 82,6 | 82,0 | 78,9 | 82,5 | 82,0 | 78,9 | 82,5 | 82,0 | 78,9 | 82,5 | 82,0 | 78,9 | 3 |
| 1,1 | 84,0 | 84,7 | 83,4 | 84,4 | 84,5 | 82,5 | 84,3 | 84,0 | 81,4 | 84,0 | 84,0 | 81,4 | 84,0 | 84,0 | 81,4 | 84,0 | 84,0 | 81,4 | |
| 1,5 | 85,6 | 86,5 | 85,8 | 85,9 | 86,4 | 84,9 | 86,0 | 86,0 | 84,0 | 85,6 | 86,0 | 84,0 | 85,6 | 86,0 | 84,0 | 85,6 | 86,0 | 84,0 | |
| 2,2 | 86,5 | 87,4 | 86,8 | 86,4 | 86,9 | 85,7 | 86,6 | 86,7 | 85,0 | 86,4 | 86,7 | 85,0 | 86,4 | 86,7 | 85,0 | 86,4 | 86,7 | 85,0 | |
| 3 | 87,2 | 88,5 | 88,3 | 87,5 | 88,2 | 87,5 | 87,5 | 87,8 | 86,4 | 87,2 | 87,8 | 86,4 | 87,2 | 87,8 | 86,4 | 87,2 | 87,8 | 86,4 | |

** Condizioni operative riferite esclusivamente al motore. Per l'elettropompa valgono i limiti previsti nel manuale d'uso

1-10VM-ie3-mott-2p50_b_te

VM SERIES PUMPS (ErP 2009/125/EC)

With the **Regulation (EU) N. 547/2012**, the European Commission has established the requirements of ecodesign for some typologies of pumps used for pumping clean water, placed on the market and operated as stand-alone units or as parts of other products.

For vertical multi-stage pumps (MS-V for the Regulations), the requirements refers to:

- just the pump and not the pump and motor assembly (electric or combustion);
- pumps with:
 - a nominal pressure PN not higher than 25 bar (2500 kPa);
 - a speed of 2900 min⁻¹ (for electric pumps this means 50 Hz 2-pole electric motors);
 - a maximum flow of 100 m³/h;
- use with clean water at a temperature ranging from -10°C to 120°C (the test is performed with cold water at a temperature not higher than 40°C).

This regulation states that water pumps shall have index MEI coming from a dedicated formula which considers hydraulic efficiency values at 'best efficiency point' (BEP), 75 % of the flow at BEP (Part load – PL) and 110 % of the flow at BEP (Over load – OL).

The Regulation also establishes the following deadline:

| from | minimum efficiency index (MEI) |
|------------------------------|--------------------------------|
| 1 st January 2015 | MEI ≥ 0,4 |

Regulation (EU) n. 547/2012 – Annex II – point 2 (Product information requirements)

- 1) Minimum efficiency index: see the MEI column in the tables in the *General Characteristics* section.
- 2) The benchmark for most efficient water pumps is MEI ≥ 0,70.
- 3) Year of manufacture: see date on rating plate (≥ 2013).
- 4) Manufacturer: Xylem Service Italia Srl - Reg. No 07520560967 - Montecchio Maggiore, Vicenza, Italy.
- 5) Product type: see the PUMP TYPE column in the tables in the *Hydraulic performance* section.
- 6) Hydraulic pump efficiency with trimmed impeller: not applicable to these products.
- 7) Pump performance curves, including the performance curve: see the *Operating Characteristics* graphs in the following pages.
- 8) The efficiency of a pump with a trimmed impeller is usually lower than that of a pump with the full impeller diameter. The trimming of the impeller will adapt the pump to a fixed duty point, leading to reduced energy consumption. The minimum efficiency index (MEI) is based on the full impeller diameter.
- 9) The operation of this water pump with variable duty points may be more efficient and economic when controlled, for example, by the use of a variable speed drive that matches the pump duty to the system.
- 10) Information relevant for disassembly, recycling or disposal at end-of-life: observe the current laws and by-laws governing sorted waste disposal. Consult the product operating manual.
- 11) "Designed for use below – 10 °C only": note not applicable to these products.
- 12) "Designed for use above 120 °C only": note not applicable to these products.
- 13) Specific instructions for pumps as per points 11 and 12: not applicable to these products.
- 14) "Information on benchmark efficiency is available at": www.europump.org (Ecodesign section).
- 15) The benchmark efficiency graphs with MEI = 0.7 and MEI = 0.4 are available at www.europump.org, (Ecodesign, Efficiency charts). Refer to "Multistage Vertical 2900 rpm"

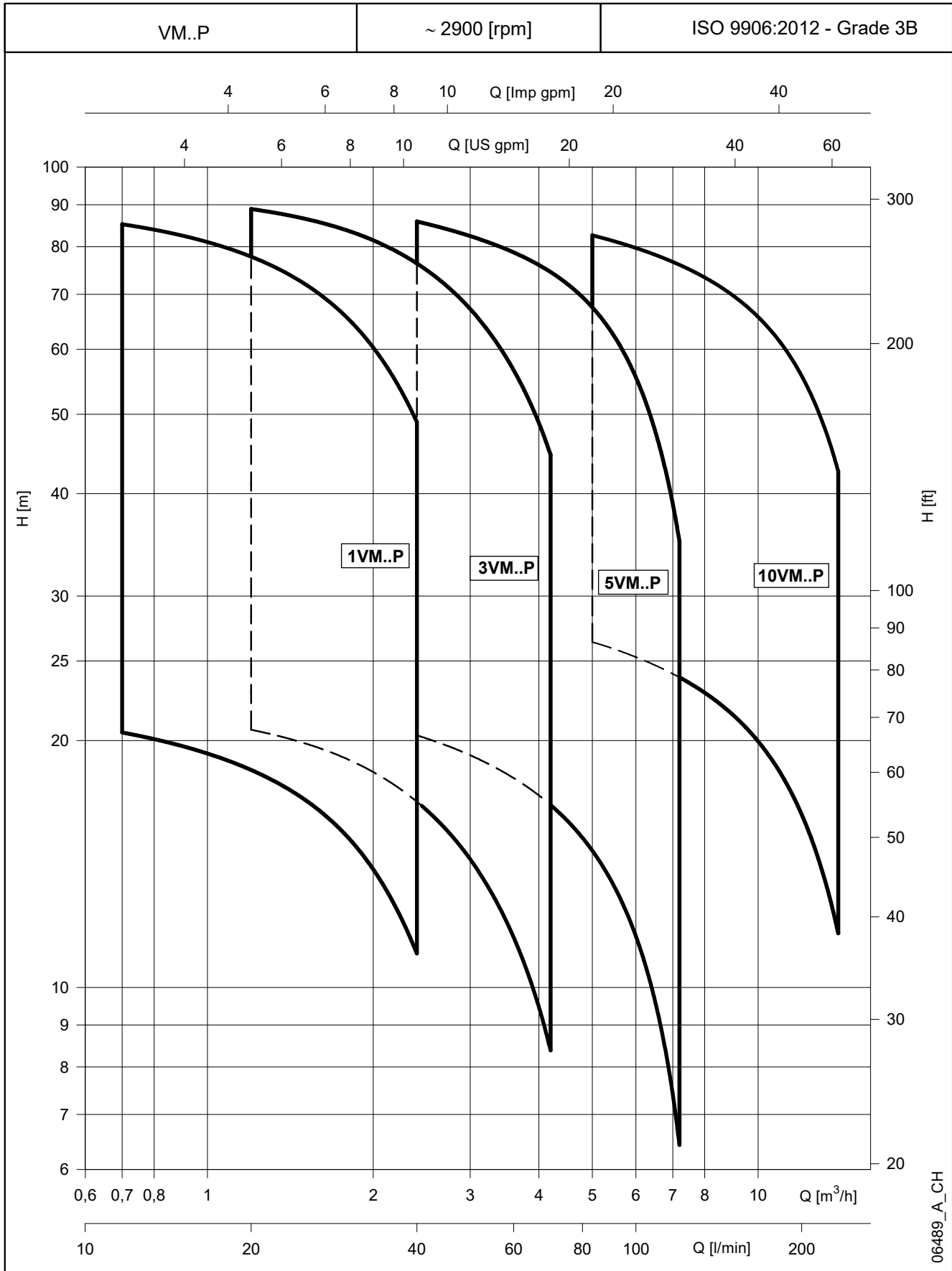
VM..P SERIES
HYDRAULIC PERFORMANCE RANGE AT 50 Hz, 2 POLES

06489_A_CH

VM..P SERIES

HYDRAULIC PERFORMANCE TABLE AT 50 Hz, 2 POLES

| PUMP TYPE VM..P | VERSION | MOTOR | | ELECTRIC PUMP | | | Q = DELIVERY | | | | | | | | | |
|---|---------|----------------------|------------------|------------------------|------|-----------|--------------|---------------------|------|------|------|------|------|------|------|------|
| | | P _N kW | TYPE | * P ₁ kW | * I | | l/min 0 | 11,7 | 16,0 | 21,0 | 26,0 | 31,0 | 36,0 | 40,0 | | |
| | | | | | | 220-240 V | 380-415 V | m ³ /h 0 | 0,7 | 1,0 | 1,3 | 1,6 | 1,9 | 2,2 | 2,4 | |
| H = TOTAL HEAD IN METRES OF COLUMN OF WATER | | | | | | | | | | | | | | | | |
| 1VM03 | 1 ~ | 0,55 | SM71HM../1055 E2 | 0,51 | 2,28 | - | - | 34,1 | 31,6 | 30,3 | 28,4 | 26,2 | 23,6 | 20,6 | 18,0 | |
| 1VM04 | | 0,55 | SM71HM../1055 E2 | 0,61 | 2,64 | - | - | 45,0 | 41,5 | 39,6 | 37,1 | 34,1 | 30,5 | 26,5 | 23,0 | |
| 1VM05 | | 0,55 | SM71HM../1055 E2 | 0,71 | 3,04 | - | - | 55,6 | 51,1 | 48,6 | 45,3 | 41,5 | 37,0 | 32,0 | 27,6 | |
| 1VM06 | | 0,75 | SM80HM../1075 E2 | 0,85 | 3,81 | - | - | 68,0 | 63,0 | 60,3 | 56,5 | 52,1 | 46,8 | 40,8 | 35,5 | |
| 1VM07 | | 0,75 | SM80HM../1075 E2 | 0,96 | 4,25 | - | - | 78,9 | 72,9 | 69,6 | 65,2 | 59,9 | 53,6 | 46,6 | 40,5 | |
| 1VM08 | | 1,1 | SM80HM../1115 E2 | 1,13 | 4,96 | - | - | 91,0 | 84,4 | 80,8 | 75,9 | 69,9 | 62,9 | 54,9 | 47,9 | |
| 1VM02 | | 3 ~ | 0,30 | SM63HM../303 | 0,34 | 1,87 | 1,08 | - | 22,5 | 20,7 | 19,7 | 18,4 | 16,9 | 15,1 | 13,1 | 11,3 |
| 1VM03 | | | 0,30 | SM63HM../303 | 0,46 | 1,94 | 1,12 | - | 32,6 | 29,6 | 28,1 | 26,1 | 23,7 | 21,0 | 17,9 | 15,4 |
| 1VM04 | 0,40 | | SM63HM../304 | 0,56 | 2,32 | 1,34 | - | 43,9 | 39,9 | 37,9 | 35,2 | 32,1 | 28,4 | 24,4 | 20,9 | |
| 1VM05 | 0,50 | | SM63HM../305 | 0,67 | 2,61 | 1,51 | - | 54,2 | 49,0 | 46,3 | 42,9 | 38,9 | 34,4 | 29,3 | 25,0 | |
| 1VM06 | 0,75 | | SM80HM../307 E3 | 0,80 | 2,75 | 1,59 | - | 68,5 | 63,6 | 60,9 | 57,2 | 52,7 | 47,5 | 41,5 | 36,2 | |
| 1VM07 | 0,75 | | SM80HM../307 E3 | 0,92 | 2,97 | 1,71 | - | 79,5 | 73,6 | 70,4 | 66,0 | 60,7 | 54,6 | 47,6 | 41,5 | |
| 1VM08 | 1,1 | | SM80HM../311 E3 | 1,05 | 3,68 | 2,12 | - | 91,6 | 85,2 | 81,7 | 76,8 | 70,9 | 63,9 | 55,9 | 48,9 | |

| PUMP TYPE VM..P | VERSION | MOTOR | | ELECTRIC PUMP | | | Q = DELIVERY | | | | | | | | |
|---|---------|----------------------|------------------|------------------------|------|-----------|--------------|---------------------|------|------|------|------|------|------|------|
| | | P _N kW | TYPE | * P ₁ kW | * I | | l/min 0 | 20,0 | 28,0 | 36,0 | 44,0 | 52,0 | 60,0 | 70,0 | |
| | | | | | | 220-240 V | 380-415 V | m ³ /h 0 | 1,2 | 1,7 | 2,2 | 2,6 | 3,1 | 3,6 | 4,2 |
| H = TOTAL HEAD IN METRES OF COLUMN OF WATER | | | | | | | | | | | | | | | |
| 3VM02 | 1 ~ | 0,55 | SM71HM../1055 E2 | 0,49 | 2,20 | - | - | 24,1 | 22,1 | 21,1 | 19,7 | 17,9 | 15,9 | 13,6 | 10,4 |
| 3VM03 | | 0,55 | SM71HM../1055 E2 | 0,62 | 2,66 | - | - | 35,3 | 32,5 | 30,9 | 28,8 | 26,2 | 23,3 | 20,1 | 15,6 |
| 3VM04 | | 0,55 | SM71HM../1055 E2 | 0,75 | 3,22 | - | - | 46,5 | 42,4 | 40,1 | 37,2 | 33,6 | 29,7 | 25,3 | 19,4 |
| 3VM05 | | 0,75 | SM80HM../1075 E2 | 0,94 | 4,15 | - | - | 59,1 | 54,5 | 51,8 | 48,3 | 44,1 | 39,2 | 33,8 | 26,4 |
| 3VM06 | | 1,1 | SM80HM../1115 E2 | 1,14 | 5,02 | - | - | 71,4 | 66,2 | 63,0 | 58,9 | 53,9 | 48,1 | 41,6 | 32,7 |
| 3VM07 | | 1,1 | SM80HM../1115 E2 | 1,29 | 5,66 | - | - | 82,9 | 76,5 | 72,8 | 67,9 | 62,0 | 55,1 | 47,6 | 37,1 |
| 3VM08 | | 1,1 | SM80HM../1115 E2 | 1,43 | 6,35 | - | - | 94,3 | 86,7 | 82,4 | 76,6 | 69,7 | 61,9 | 53,2 | 41,3 |
| 3VM02 | | 3 ~ | 0,30 | SM63HM../303 | 0,43 | 1,92 | 1,11 | - | 23,2 | 20,9 | 19,6 | 18,1 | 16,2 | 14,1 | 11,9 |
| 3VM03 | 0,40 | | SM63HM../304 | 0,57 | 2,32 | 1,34 | - | 34,5 | 31,3 | 29,4 | 27,2 | 24,5 | 21,6 | 18,4 | 13,9 |
| 3VM04 | 0,50 | | SM63HM../305 | 0,71 | 2,67 | 1,54 | - | 45,3 | 40,6 | 38,0 | 34,9 | 31,3 | 27,3 | 23,0 | 17,1 |
| 3VM05 | 0,75 | | SM80HM../307 E3 | 0,90 | 2,93 | 1,69 | - | 59,5 | 55,0 | 52,4 | 49,0 | 44,8 | 39,9 | 34,5 | 27,1 |
| 3VM06 | 1,1 | | SM80HM../311 E3 | 1,08 | 3,71 | 2,14 | - | 71,8 | 66,7 | 63,7 | 59,7 | 54,7 | 48,9 | 42,5 | 33,5 |
| 3VM07 | 1,1 | | SM80HM../311 E3 | 1,24 | 4,02 | 2,32 | - | 83,5 | 77,3 | 73,7 | 68,9 | 63,1 | 56,3 | 48,8 | 38,3 |
| 3VM08 | 1,5 | | SM80HM../315 E3 | 1,41 | 4,83 | 2,79 | - | 95,8 | 88,9 | 84,9 | 79,5 | 72,9 | 65,2 | 56,6 | 44,6 |

| PUMP TYPE VM..P | VERSION | MOTOR | | ELECTRIC PUMP | | | Q = DELIVERY | | | | | | | | |
|---|---------|----------------------|-------------------|------------------------|------|-----------|--------------|---------------------|------|------|------|------|------|------|------|
| | | P _N kW | TYPE | * P ₁ kW | * I | | l/min 0 | 40,0 | 53,0 | 66,0 | 79,0 | 92,0 | 105 | 120 | |
| | | | | | | 220-240 V | 380-415 V | m ³ /h 0 | 2,4 | 3,2 | 4,0 | 4,7 | 5,5 | 6,3 | 7,2 |
| H = TOTAL HEAD IN METRES OF COLUMN OF WATER | | | | | | | | | | | | | | | |
| 5VM02 | 1 ~ | 0,55 | SM71HM../1055 E2 | 0,58 | 2,53 | - | - | 24,4 | 21,2 | 19,8 | 18,3 | 16,5 | 14,4 | 11,7 | 7,7 |
| 5VM03 | | 0,55 | SM71HM../1055 E2 | 0,77 | 3,32 | - | - | 36,0 | 30,4 | 28,4 | 26,3 | 23,8 | 20,5 | 16,4 | 10,4 |
| 5VM04 | | 0,75 | SM80HM../1075 E2 | 1,02 | 4,52 | - | - | 48,6 | 41,6 | 39,2 | 36,5 | 33,2 | 28,9 | 23,5 | 15,5 |
| 5VM05 | | 1,1 | SM80HM../1115 E2 | 1,27 | 5,60 | - | - | 61,0 | 52,6 | 49,6 | 46,3 | 42,3 | 37,0 | 30,2 | 20,2 |
| 5VM06 | | 1,1 | SM80HM../1115 E2 | 1,48 | 6,56 | - | - | 72,9 | 62,3 | 58,6 | 54,5 | 49,5 | 43,1 | 34,9 | 22,9 |
| 5VM07 | | 1,5 | PLM90HM../1155 E2 | 1,75 | 7,93 | - | - | 85,8 | 74,4 | 70,3 | 65,8 | 60,2 | 52,9 | 43,4 | 29,4 |
| 5VM08 | | 1,5 | PLM90HM../1155 E2 | 1,96 | 8,87 | - | - | 97,8 | 84,3 | 79,6 | 74,3 | 67,8 | 59,4 | 48,5 | 32,6 |
| 5VM02 | | 3 ~ | 0,40 | SM63HM../304 | 0,53 | 2,29 | 1,32 | - | 24,1 | 20,4 | 18,9 | 17,3 | 15,5 | 13,3 | 10,5 |
| 5VM03 | 0,50 | | SM63HM../305 | 0,73 | 2,69 | 1,55 | - | 35,3 | 28,9 | 26,8 | 24,5 | 21,9 | 18,6 | 14,4 | 8,4 |
| 5VM04 | 1,1 | | SM80HM../311 E3 | 1,00 | 3,57 | 2,06 | - | 49,3 | 43,0 | 40,7 | 38,2 | 35,1 | 30,9 | 25,6 | 17,6 |
| 5VM05 | 1,1 | | SM80HM../311 E3 | 1,22 | 3,99 | 2,30 | - | 61,4 | 53,2 | 50,3 | 47,1 | 43,1 | 37,9 | 31,1 | 21,1 |
| 5VM06 | 1,5 | | SM80HM../315 E3 | 1,45 | 4,92 | 2,84 | - | 73,8 | 64,1 | 60,7 | 56,9 | 52,1 | 45,9 | 37,8 | 25,8 |
| 5VM07 | 1,5 | | SM80HM../315 E3 | 1,67 | 5,35 | 3,09 | - | 85,8 | 74,2 | 70,1 | 65,6 | 60,0 | 52,7 | 43,2 | 29,2 |
| 5VM08 | 2,2 | | PLM90HM../322 E3 | 1,94 | 6,77 | 3,91 | - | 98,6 | 85,9 | 81,4 | 76,3 | 70,0 | 61,8 | 51,0 | 35,0 |

| PUMP TYPE VM..P | VERSION | MOTOR | | ELECTRIC PUMP | | | Q = DELIVERY | | | | | | | | |
|---|---------|----------------------|-------------------|------------------------|------|-----------|--------------|---------------------|------|------|------|------|------|------|------|
| | | P _N kW | TYPE | * P ₁ kW | * I | | l/min 0 | 83,3 | 108 | 133 | 158 | 183 | 208 | 233 | |
| | | | | | | 220-240 V | 380-415 V | m ³ /h 0 | 5,0 | 6,5 | 8,0 | 9,5 | 11,0 | 12,5 | 14,0 |
| H = TOTAL HEAD IN METRES OF COLUMN OF WATER | | | | | | | | | | | | | | | |
| 10VM02 | 1 ~ | 1,1 | SM80HM../1115 E2 | 1,28 | 5,65 | - | - | 30,7 | 27,0 | 25,4 | 23,7 | 21,6 | 19,1 | 16,1 | 12,6 |
| 10VM03 | | 1,5 | PLM90HM../1155 E2 | 1,81 | 8,22 | - | - | 46,2 | 41,4 | 39,3 | 36,9 | 34,1 | 30,8 | 26,6 | 21,5 |
| 10VM02 | 3 ~ | 1,1 | SM80HM../311 E3 | 1,22 | 4,00 | 2,31 | - | 30,8 | 27,3 | 25,8 | 24,0 | 22,0 | 19,5 | 16,5 | 13,0 |
| 10VM03 | | 1,5 | SM80HM../315 E3 | 1,75 | 5,48 | 3,17 | - | 46,2 | 41,4 | 39,2 | 36,8 | 34,0 | 30,7 | 26,5 | 21,4 |
| 10VM04 | | 2,2 | PLM90HM../322 E3 | 2,33 | 7,54 | 4,35 | - | 61,8 | 55,4 | 52,6 | 49,4 | 45,8 | 41,3 | 35,8 | 29,0 |
| 10VM05 | | 3 | PLM90HM../330 E3 | 2,91 | 10,0 | 5,80 | - | 77,3 | 69,5 | 66,0 | 62,1 | 57,5 | 51,9 | 45,0 | 36,5 |
| 10VM06 | | 3 | PLM90HM../330 E3 | 3,44 | 11,1 | 6,41 | - | 92,5 | 82,6 | 78,3 | 73,5 | 67,9 | 61,1 | 52,8 | 42,6 |

Hydraulic performances in compliance with ISO 9906:2012 - Grade 3B (ex ISO 9906:1999 - Annex A)

1-10vm-p-2p50-en_b_th

* Maximum value in specified range: P₁ = input power; I = input current.

1VM..P SERIES

DIMENSIONS AND WEIGHTS AT 50 HZ, 2 POLES

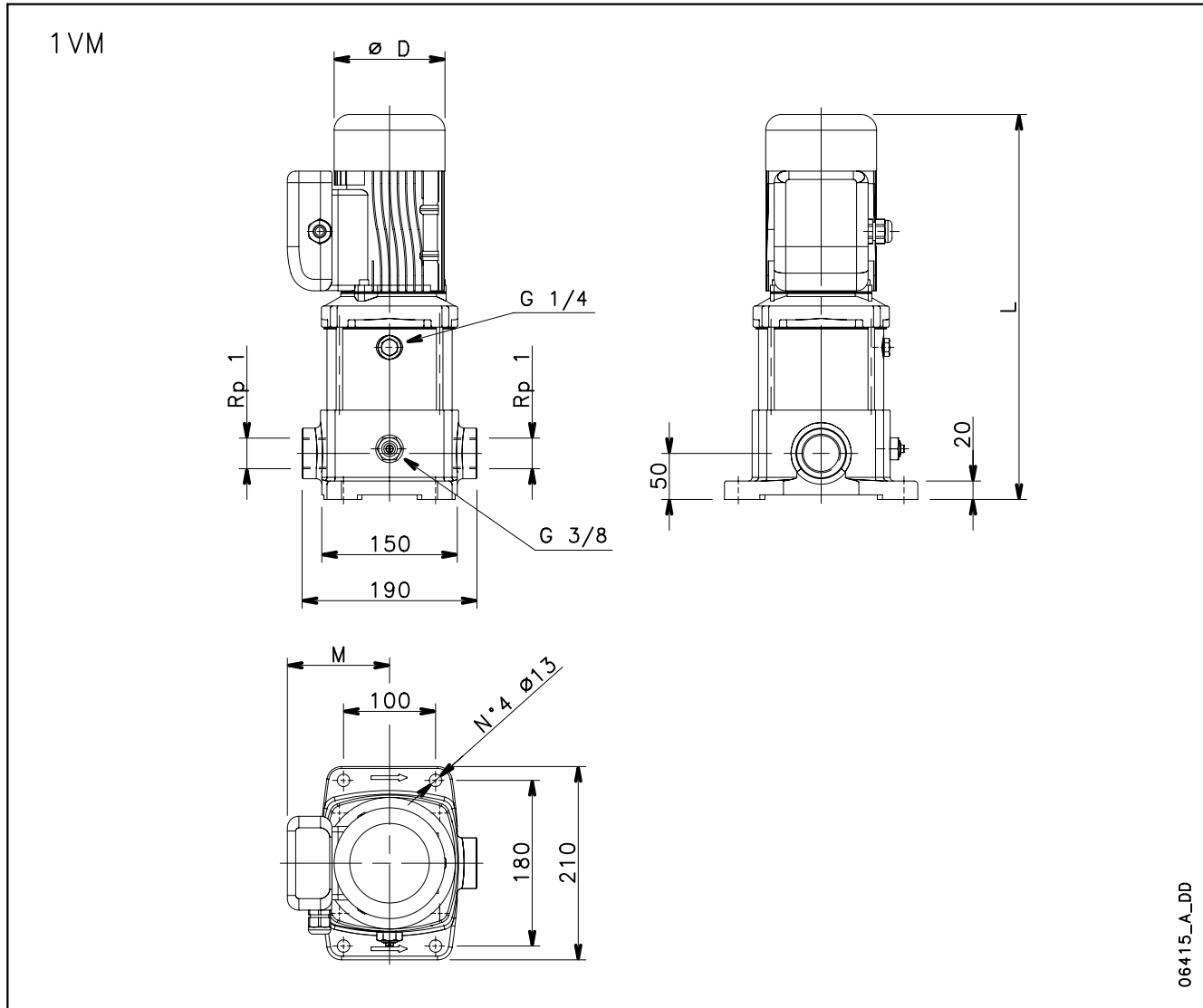

| PUMP TYPE | VERSION | MOTOR | | DIMENSIONS (mm) | | | PN bar | WEIGHT kg |
|-----------|--------------|-------|------|-----------------|-----|-----|--------|-----------|
| | | kW | SIZE | D | M | L | | |
| 1VM03 | SINGLE-PHASE | 0,55 | 71 | 140 | 121 | 393 | 10 | 14 |
| 1VM04 | | 0,55 | 71 | 140 | 121 | 413 | 10 | 15 |
| 1VM05 | | 0,55 | 71 | 140 | 121 | 433 | 10 | 15 |
| 1VM06 | | 0,75 | 80 | 155 | 137 | 497 | 10 | 15 |
| 1VM07 | | 0,75 | 80 | 155 | 137 | 517 | 10 | 16 |
| 1VM08 | | 1,1 | 80 | 155 | 137 | 537 | 10 | 17 |

| | | | | | | | | |
|-------|-------------|------|----|-----|-----|-----|----|----|
| 1VM02 | THREE-PHASE | 0,30 | 63 | 120 | 111 | 379 | 10 | 11 |
| 1VM03 | | 0,30 | 63 | 120 | 111 | 379 | 10 | 11 |
| 1VM04 | | 0,40 | 63 | 120 | 111 | 399 | 10 | 12 |
| 1VM05 | | 0,50 | 63 | 120 | 111 | 419 | 10 | 13 |
| 1VM06 | | 0,75 | 80 | 155 | 129 | 497 | 10 | 18 |
| 1VM07 | | 0,75 | 80 | 155 | 129 | 517 | 10 | 19 |
| 1VM08 | | 1,1 | 80 | 155 | 129 | 537 | 10 | 20 |

1vm-2p50-en_b_td

1VM..P SERIES

OPERATING CHARACTERISTICS AT 50 Hz, 2 POLES

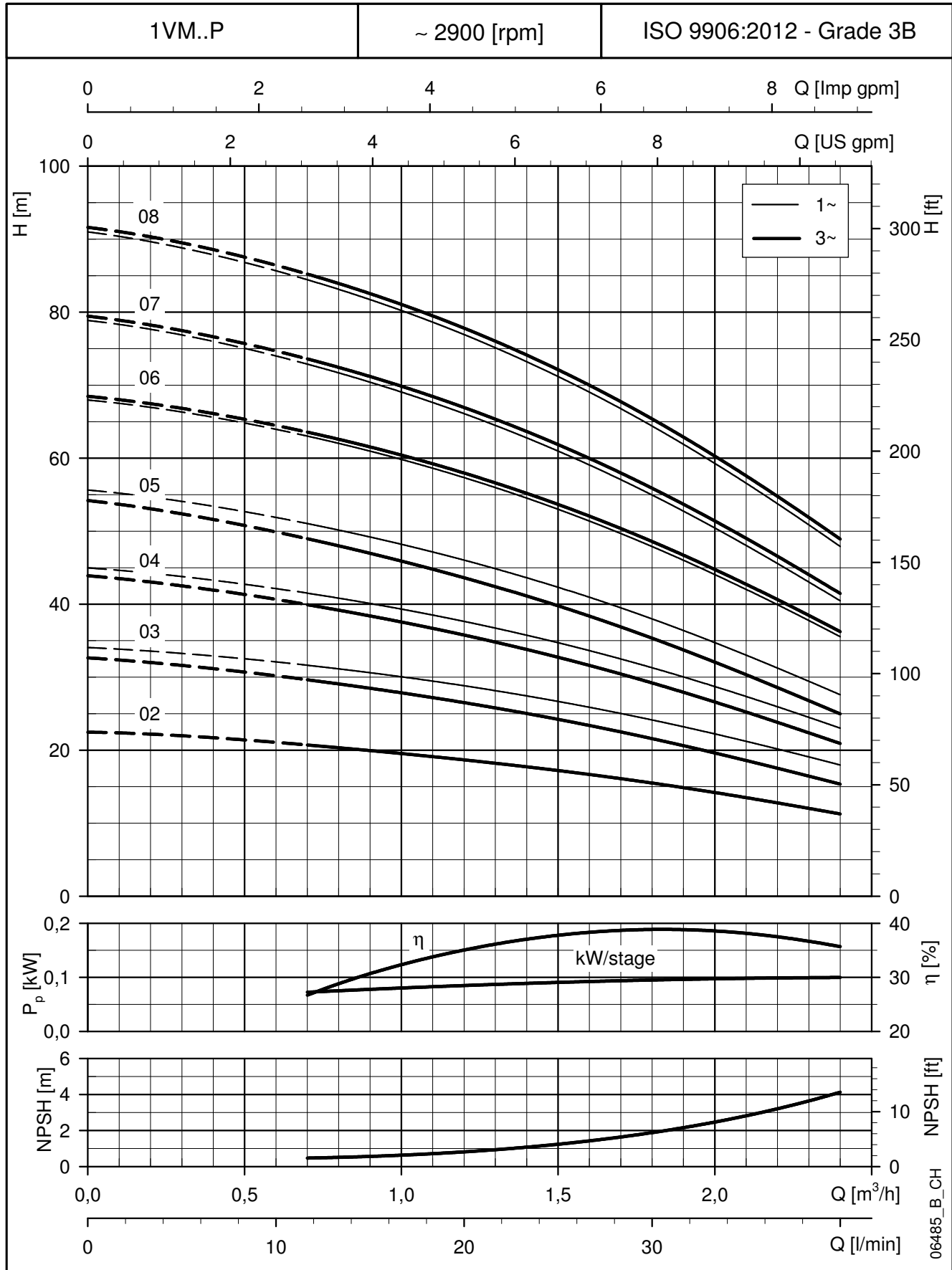

These performances are valid for liquids with density $\rho = 1 \text{ Kg/dm}^3$ and kinematic viscosity $\nu = 1 \text{ mm}^2/\text{sec}$.

3VM..P SERIES DIMENSIONS AND WEIGHTS AT 50 HZ, 2 POLES

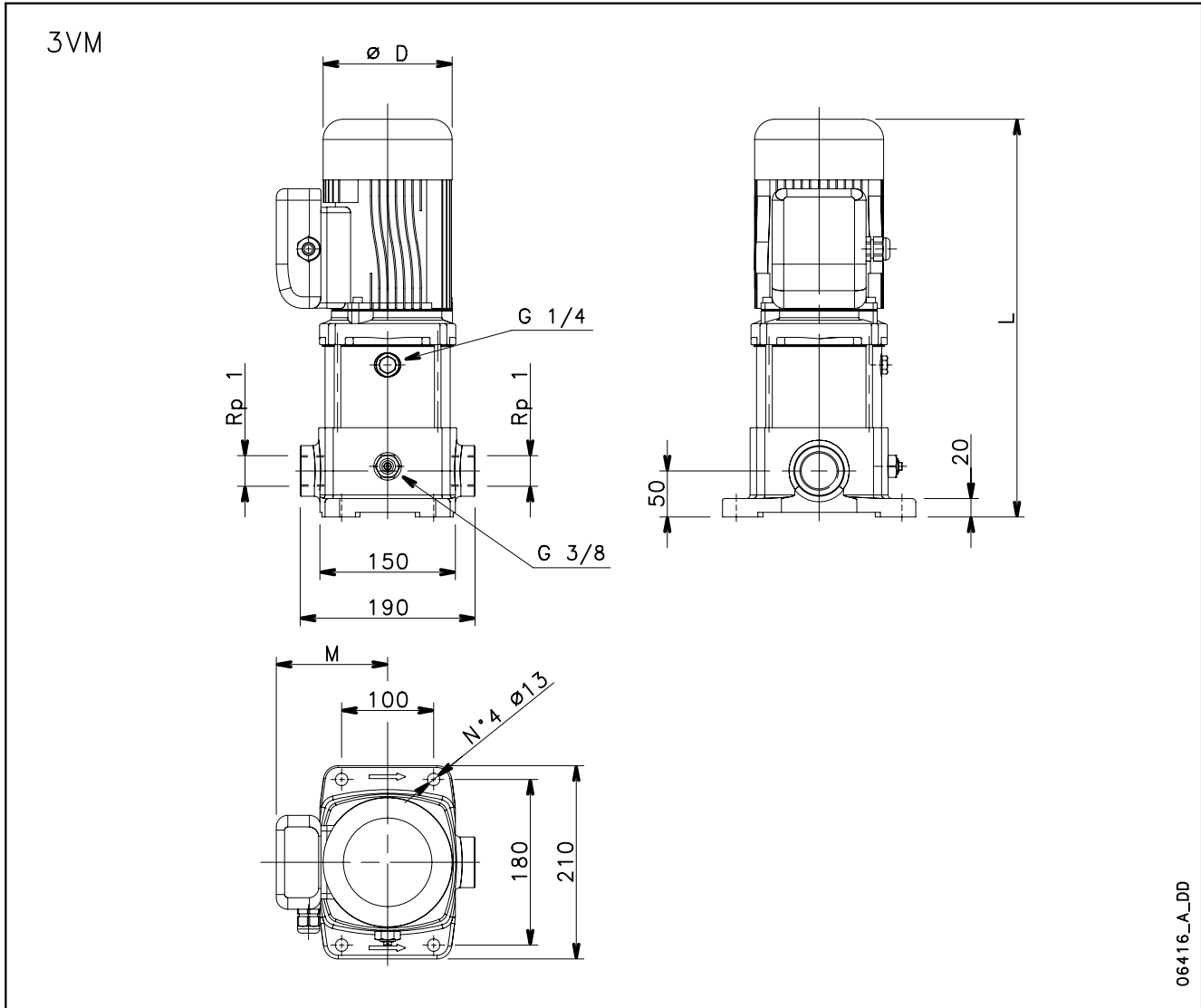

06416_A_DD

| PUMP TYPE | VERSION | MOTOR | | DIMENSIONS (mm) | | | PN bar | WEIGHT kg |
|-----------|--------------|-------|------|-----------------|-----|-----|--------|-----------|
| | | kW | SIZE | D | M | L | | |
| 3VM02 | SINGLE-PHASE | 0,55 | 71 | 140 | 121 | 393 | 10 | 14 |
| 3VM03 | | 0,55 | 71 | 140 | 121 | 393 | 10 | 14 |
| 3VM04 | | 0,55 | 71 | 140 | 121 | 413 | 10 | 15 |
| 3VM05 | | 0,75 | 80 | 155 | 137 | 477 | 10 | 15 |
| 3VM06 | | 1,1 | 80 | 155 | 137 | 497 | 10 | 18 |
| 3VM07 | | 1,1 | 80 | 155 | 137 | 517 | 10 | 19 |
| 3VM08 | | 1,1 | 80 | 155 | 137 | 537 | 10 | 20 |

| | | | | | | | | |
|-------|-------------|------|----|-----|-----|-----|----|----|
| 3VM02 | THREE-PHASE | 0,30 | 63 | 120 | 111 | 379 | 10 | 11 |
| 3VM03 | | 0,40 | 63 | 120 | 111 | 379 | 10 | 12 |
| 3VM04 | | 0,50 | 63 | 120 | 111 | 399 | 10 | 13 |
| 3VM05 | | 0,75 | 80 | 155 | 129 | 477 | 10 | 18 |
| 3VM06 | | 1,1 | 80 | 155 | 129 | 497 | 10 | 19 |
| 3VM07 | | 1,1 | 80 | 155 | 129 | 517 | 10 | 20 |
| 3VM08 | | 1,5 | 80 | 155 | 129 | 537 | 10 | 21 |

3vm-2p50-en_b_td

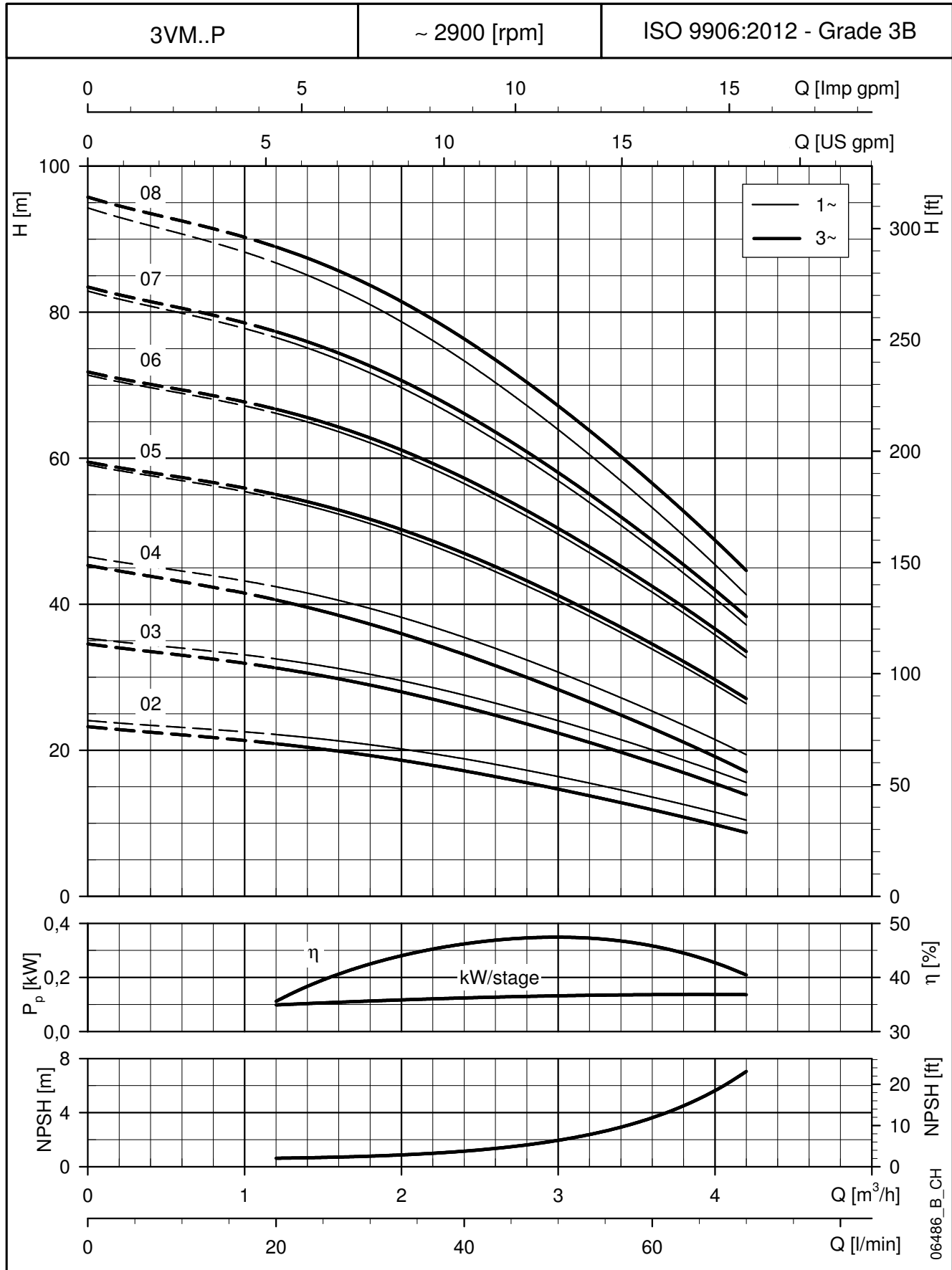
3VM..P SERIES
OPERATING CHARACTERISTICS AT 50 Hz, 2 POLES

 These performances are valid for liquids with density $\rho = 1 \text{ Kg/dm}^3$ and kinematic viscosity $\nu = 1 \text{ mm}^2/\text{sec}$.

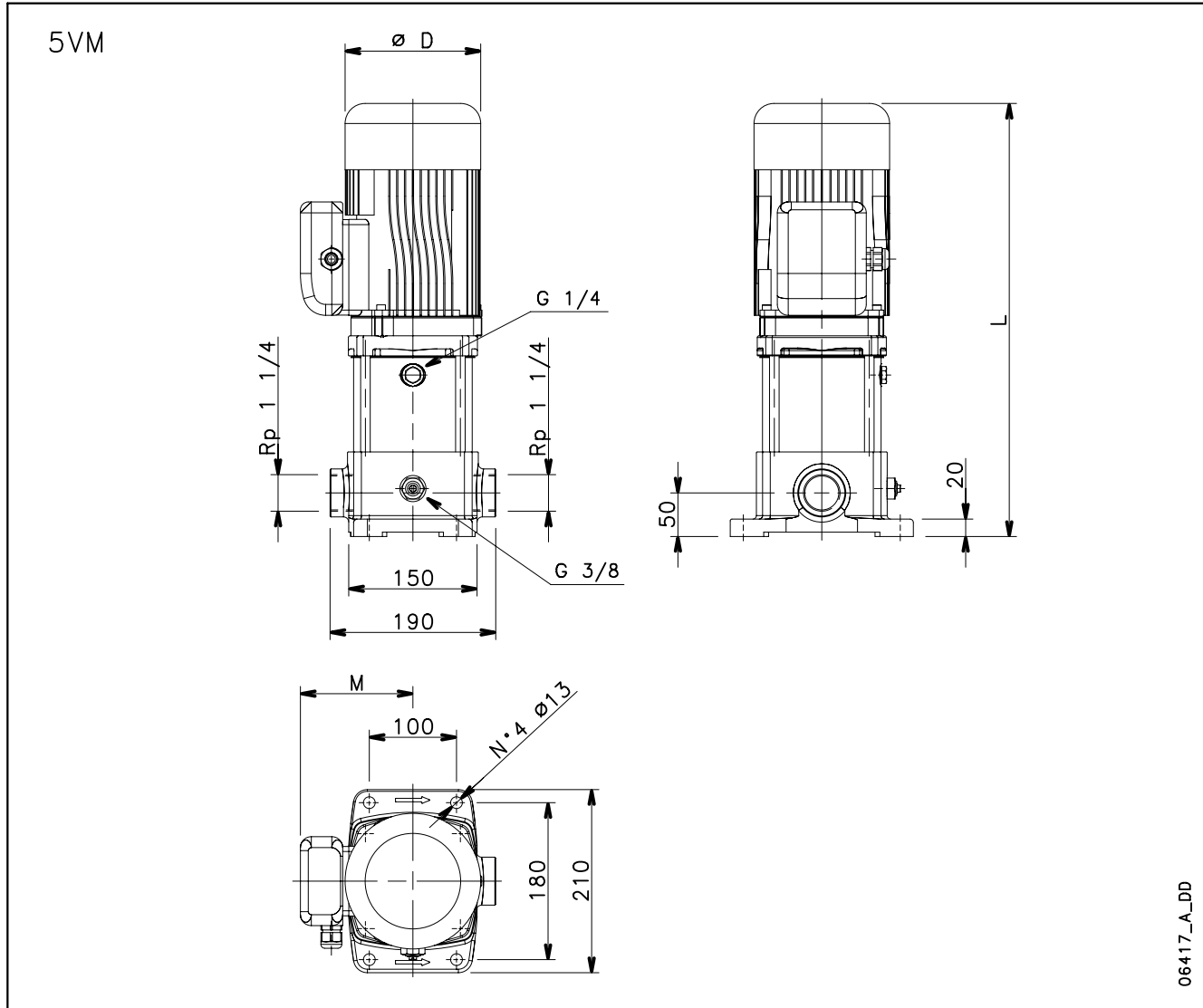
5VM..P SERIES DIMENSIONS AND WEIGHTS AT 50 HZ, 2 POLES



06417_A_DD

| PUMP TYPE | VERSION | MOTOR | | DIMENSIONS (mm) | | | PN bar | WEIGHT kg | |
|-----------|--------------|-------|------|-----------------|-----|-----|--------|-----------|----|
| | | kW | SIZE | D | M | L | | | |
| 5VM02 | SINGLE-PHASE | 0,55 | 71 | 140 | 121 | 393 | 10 | 14 | |
| 5VM03 | | 0,55 | 71 | 140 | 121 | 393 | 10 | 14 | |
| 5VM04 | | 0,75 | 80 | 155 | 137 | 457 | 10 | 19 | |
| 5VM05 | | 1,1 | 80 | 155 | 137 | 477 | 10 | 21 | |
| 5VM06 | | 1,1 | 80 | 155 | 137 | 497 | 10 | 21 | |
| 5VM07 | | 1,5 | 90 | 174 | 159 | 573 | 10 | 27 | |
| 5VM08 | | 1,5 | 90 | 174 | 174 | 159 | 593 | 10 | 27 |

| | | | | | | | | |
|-------|-------------|------|----|-----|-----|-----|----|----|
| 5VM02 | THREE-PHASE | 0,40 | 63 | 120 | 111 | 379 | 10 | 12 |
| 5VM03 | | 0,50 | 63 | 120 | 111 | 379 | 10 | 12 |
| 5VM04 | | 1,1 | 80 | 155 | 129 | 457 | 10 | 19 |
| 5VM05 | | 1,1 | 80 | 155 | 129 | 477 | 10 | 19 |
| 5VM06 | | 1,5 | 80 | 155 | 129 | 497 | 10 | 20 |
| 5VM07 | | 1,5 | 80 | 155 | 129 | 517 | 10 | 21 |
| 5VM08 | | 2,2 | 90 | 174 | 134 | 593 | 10 | 26 |

5vm-2p50-en_b_td

5VM..P SERIES

OPERATING CHARACTERISTICS AT 50 Hz, 2 POLES

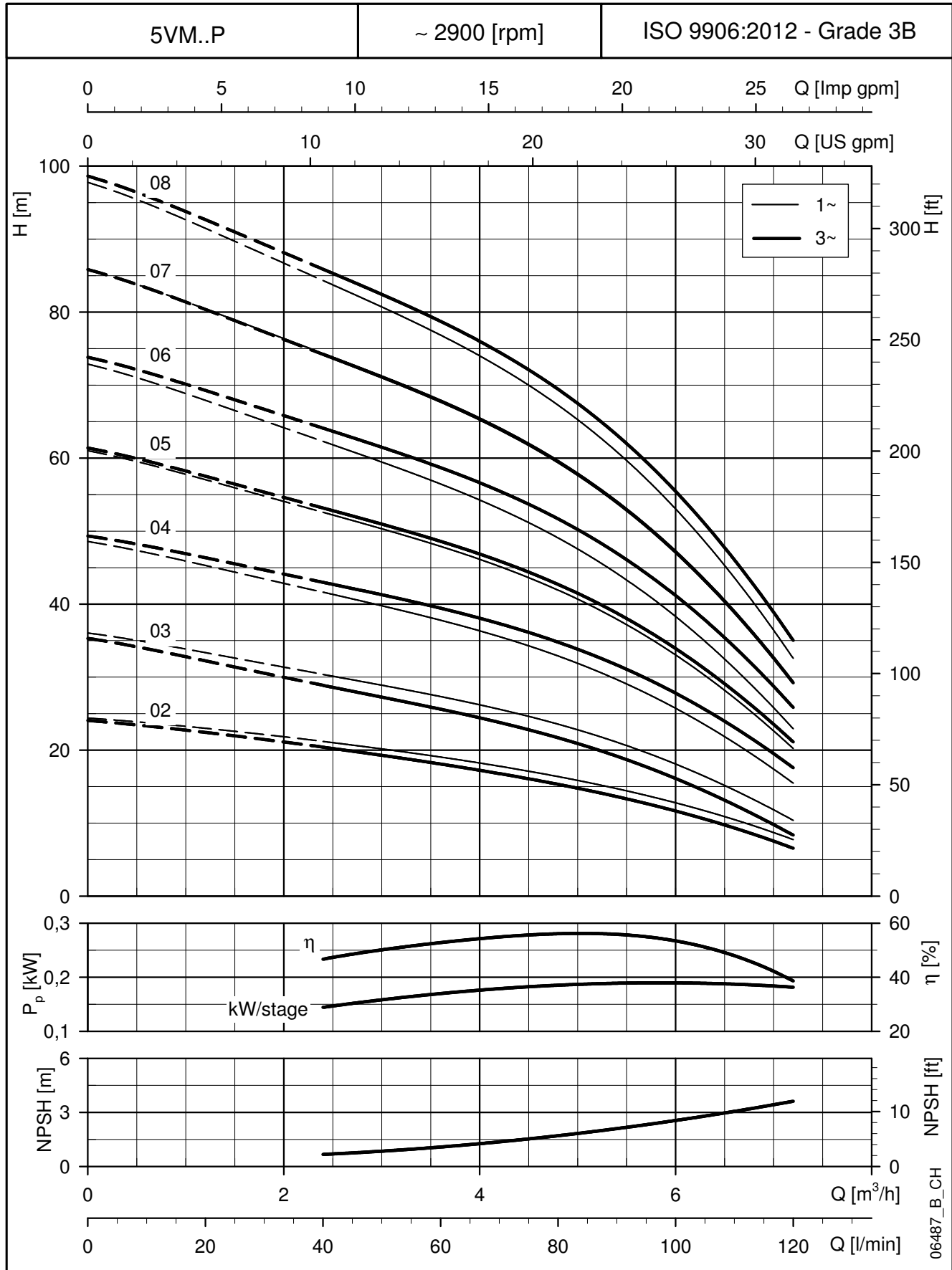

These performances are valid for liquids with density $\rho = 1 \text{ Kg/dm}^3$ and kinematic viscosity $\nu = 1 \text{ mm}^2/\text{sec}$.

10VM..P SERIES DIMENSIONS AND WEIGHTS AT 50 HZ, 2 POLES

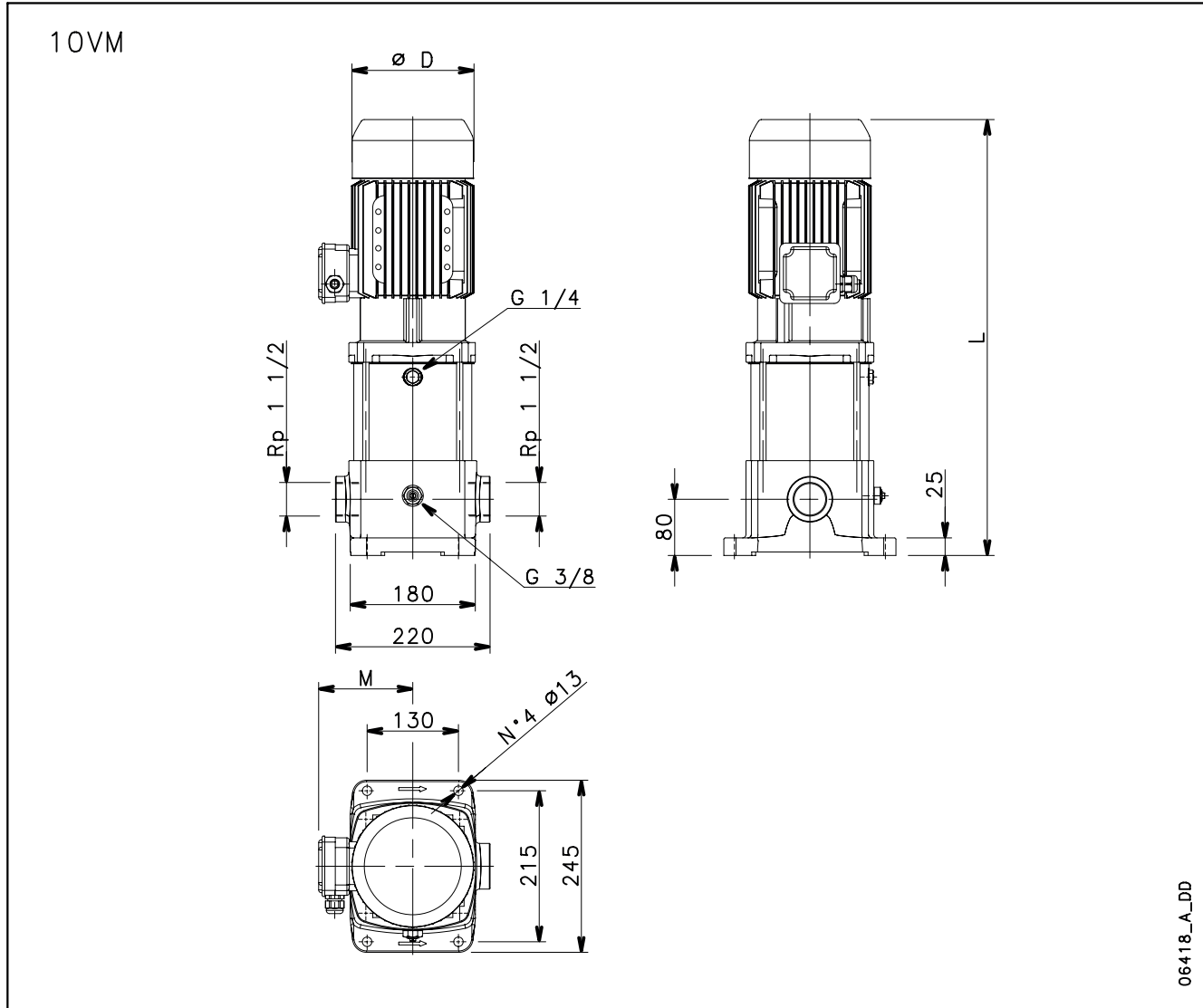

| PUMP TYPE | VERSION | MOTOR | | DIMENSIONS (mm) | | | PN bar | WEIGHT kg | |
|-----------|--------------|-------|------|-----------------|-----|-----|--------|-----------|--|
| | | kW | SIZE | D | M | L | | | |
| 10VM02 | SINGLE-PHASE | 1,1 | 80 | 155 | 137 | 501 | 10 | 23 | |
| 10VM03 | | 1,5 | 90 | 174 | 159 | 589 | 10 | 31 | |
| | | | | | | | | | |
| | | | | | | | | | |
| | | | | | | | | | |
| | | | | | | | | | |

| | | | | | | | | |
|--------|-------------|-----|----|-----|-----|-----|----|----|
| 10VM02 | THREE-PHASE | 1,1 | 80 | 155 | 129 | 501 | 10 | 23 |
| 10VM03 | | 1,5 | 80 | 155 | 129 | 533 | 10 | 25 |
| 10VM04 | | 2,2 | 90 | 174 | 134 | 621 | 10 | 31 |
| 10VM05 | | 3 | 90 | 174 | 134 | 653 | 10 | 35 |
| 10VM06 | | 3 | 90 | 174 | 134 | 685 | 10 | 36 |
| | | | | | | | | |

10vm-2p50-en_b_td

10VM..P SERIES
OPERATING CHARACTERISTICS AT 50 Hz, 2 POLES

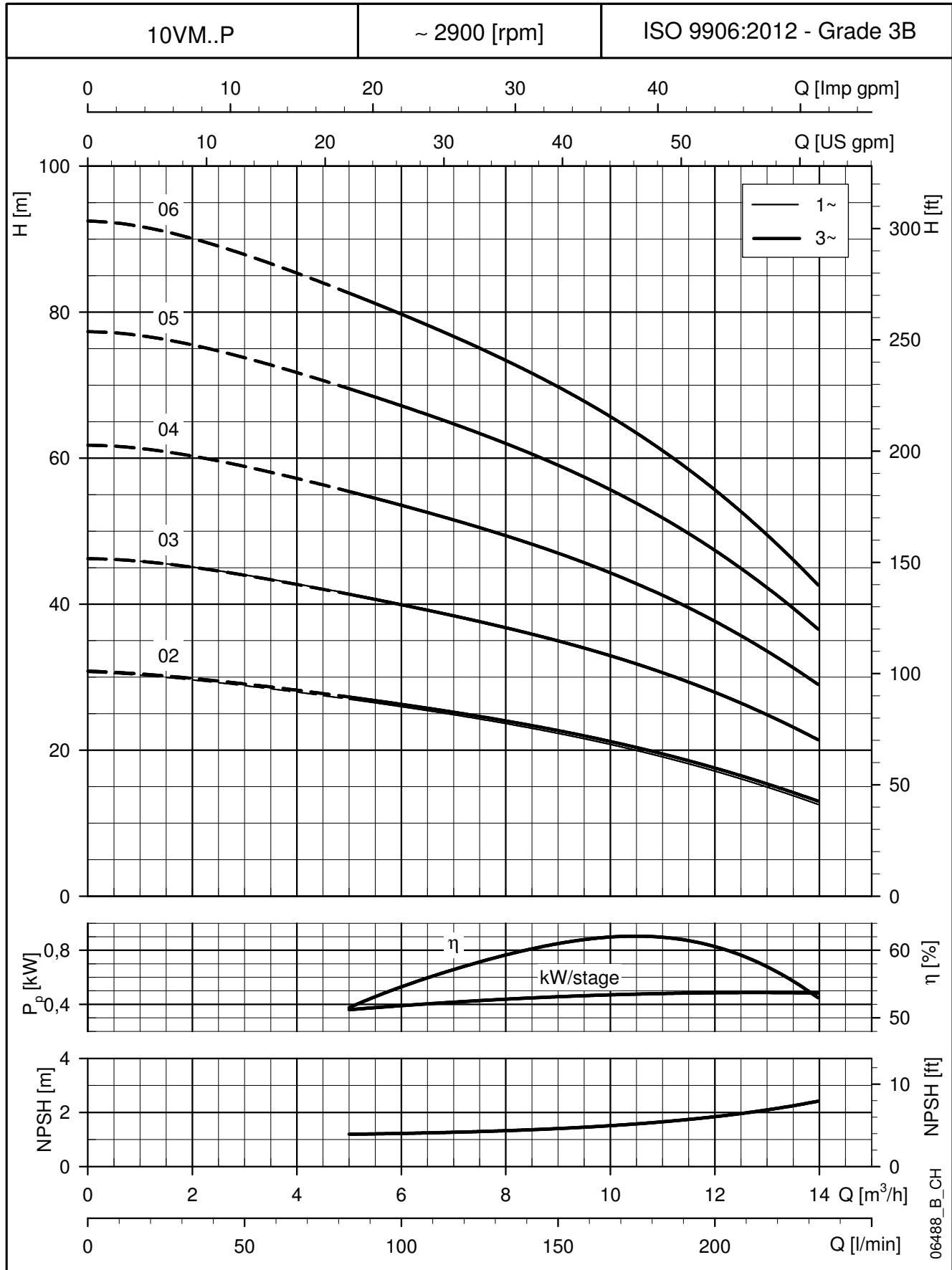

These performances are valid for liquids with density $\rho = 1 \text{ Kg/dm}^3$ and kinematic viscosity $\nu = 1 \text{ mm}^2/\text{sec}$.

VME
VERSION WITH DRIVE
AND PERMANENT
MAGNET MOTOR
(e-SM DRIVE)

VME SERIES (VM SMART)

Background and context

In every sector, from construction and industry to agriculture and building services the need for intelligent, compact and high-efficiency pumping systems is constantly growing. That's why Lowara has developed the VM series: an integrated intelligent pumping system with electronically driven, permanent magnet motor (IE5 efficiency level). The integrated control system, combined with the high performance, power and efficiency from the motor and hydraulics, guarantees impressively low operating costs. You also benefit from flexibility, precision and its ultra-compact size.

Savings

The electronics and permanent magnet motor are highly efficient and minimize power losses while transferring maximum energy to the hydraulic parts of the pump. The refined control system with integrated microprocessor adjusts the motor speed, matching the required operating point of the pump or system requirements. This reduces demand on electricity according to the required working conditions. This creates economies, especially in systems where pump demand varies over time.

Flexibility

The compact size, low loss and increased control make the VM Smart series a good choice in applications and systems where fixed speed pumps are commonly used. The VM Smart series is easy to integrate in control and regulation loops thanks to the wide availability of compatible communication protocols, including analog and digital inputs. The pump is supplied with a pressure sensor.

Ease of use and commissioning

VM Smart has an intuitive interface that guides the user through the installation, and a practical area to assist with connections. The control system is integrated and no additional external electrical panel is required.

Application sectors

- Water supply systems in residential buildings
- Air conditioning
- Water treatment plants
- Industrial installations



e-SM System

- Single-phase power supply:
208-240 V +/- 10%, 50/60 Hz
- Three-phase power supply:
- from 0,37 kW to 1,5 kW:
208-240 / 380-460 V +/- 10%, 50/60 Hz
- 2,2 kW: 380-460 V +/- 10%, 50/60 Hz
- Power up to 2,2 kW
- Protection class IP 55
- Can be linked up to 3 VM Smart pumps

Pump

- Flow rate: up to 17 m³/h
- Head: up to 100 m
- Temperature of pumped liquid: up to + 90°C
- Maximum operating pressure 10 bar (PN 10)
- The hydraulic performances meet the tolerances specified in ISO 9906:2012

Motor

- IE5 efficiency level (IEC TS 60034-30-2:2016)
- Synchronous electric motor with permanent magnets, closed structure, air-cooled (TEFC)
- Insulation class 155 (F)
- Overload protection and locked rotor with automatic reset incorporated
- Environment temperature: -20°C to + 50°C with no performance derating

Regulations (EU) 2019/1781 e 2021/341 Annex I – point 4 (Product information)

The requirements shall not apply to these variable speed drives, as they are integrated to permanent magnet motors, that aren't covered by the same regulations.

VME SERIES (VM SMART)

VM Smart series is equipped with an intelligent control that optimizes hydraulic performance while minimizing waste.

Integrated intelligence: the electronic control of the motor enables a 20% increase in performance compared to an equivalent fixed speed pump (area highlighted in figure "Integrated Intelligence").

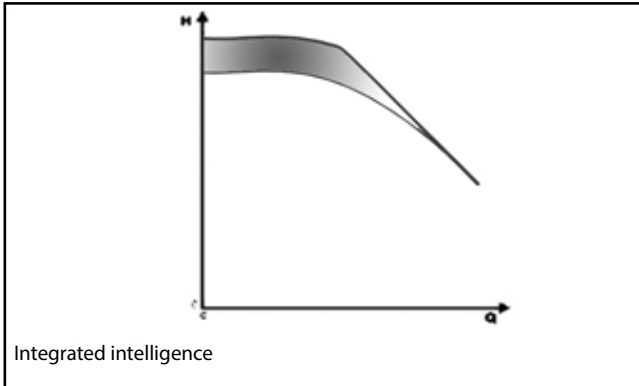

Adjustment: This is possible both at constant pressure and according to the characteristic curve of the system, based on the customer's preferences. Another option is according to an external signal or at a preset speed.

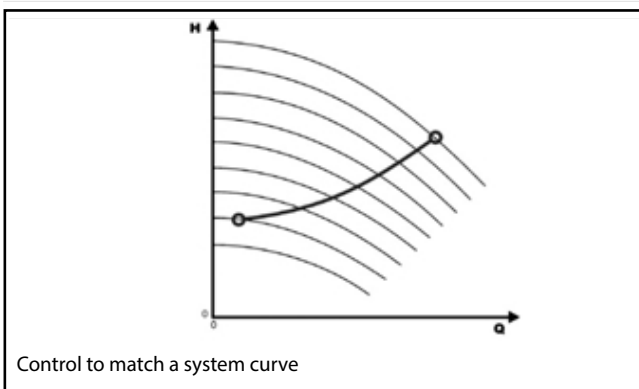
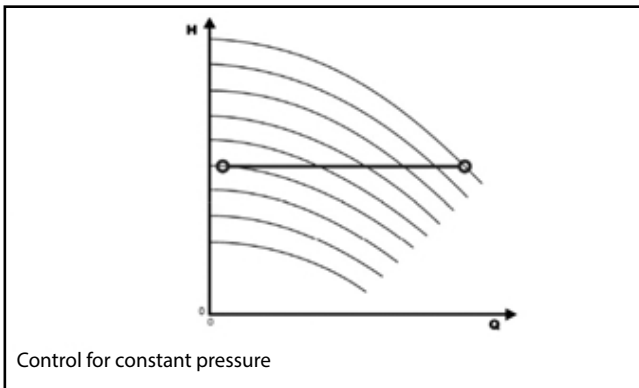

Intuitive and simple interface: you can control the unit from just three buttons, with an easy to read display for parameters and alarms, designed for complete control of system operation.

- ① Communication LED
- ② Power on LED
- ③ Unit of measure LED
- ④ Speed LED bar
- ⑤ Status LED
- ⑥ Numeric display
- ⑦ = Decrease key
- ⑧ ⏻ On/off and menu key
- ⑨ ⊕ Increase key

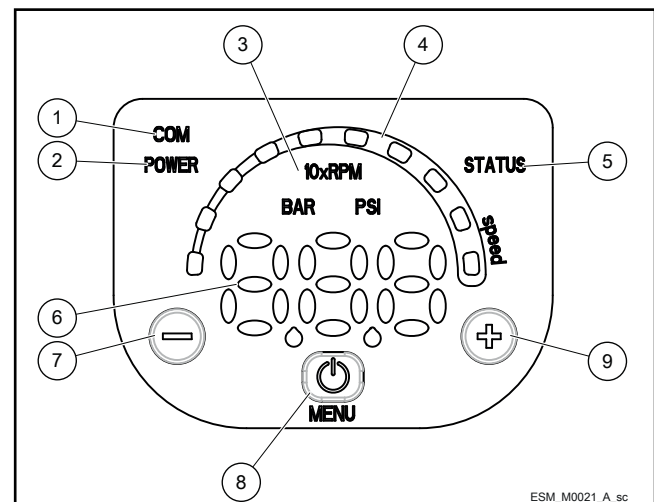

VME SERIES SINGLE PHASE TERMINAL BLOCK

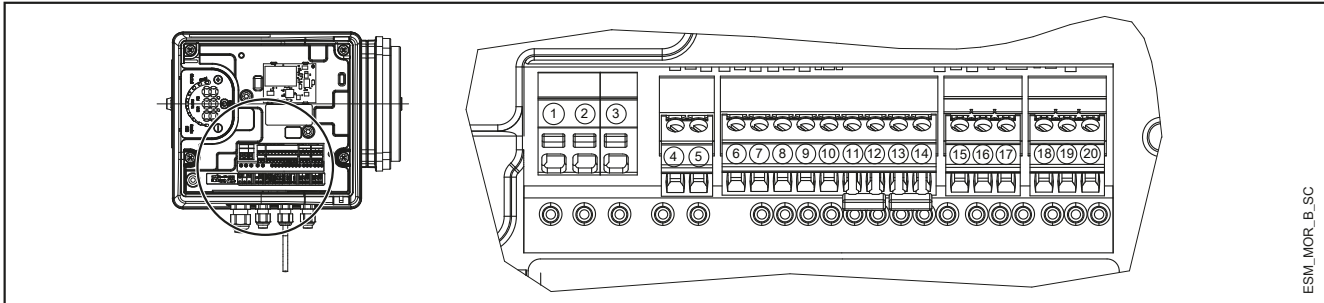

ESM_MOR_B_SC

| REF. | ITEM | DESCRIPTION |
|------|--|---|
| 4 | Fault Signal | COM - error status relay |
| 5 | | NO - error status relay |
| 6 | Auxiliary Voltage Supply | Auxiliary voltage supply +15 VDC |
| 7 | Analog input 0-10V | Actuator mode 0-10 V input |
| 8 | | GND for 0-10 V input |
| 9 | External Pressure sensor [also Differential] | Power supply external sensor +15 VDC |
| 10 | | External sensor 4-20 mA input |
| 11 | External Start/Stop | External ON/OFF input reference |
| 12 | | External ON/OFF input |
| 13 | External Lack of Water | Low water input |
| 14 | | Low water reference |
| 15 | Communication bus | RS485 port 1: RS485-1N B (-) |
| 16 | | RS485 port 1: RS485-1P A (+) |
| 17 | | Electronic GND |
| 18 | Communication bus | RS485 port 2: RS485 port 2: RS485-2N B (-) active only with optional module |
| 19 | | RS485 port 2: RS485 port 2: RS485-2P A (+) active only with optional module |
| 20 | | Electronic GND |

MorsM-en_a_sc

THREE-PHASE TERMINAL BLOCK

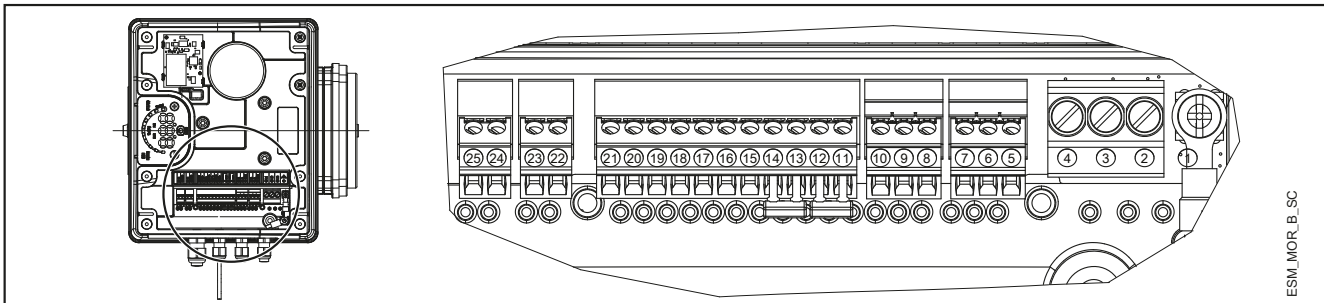

ESM_MOR_B_SC

| REF. | ITEM | DESCRIPTION |
|------|--|---|
| 5 | Communication bus | Electronic GND |
| 6 | | RS485 port 1: RS485-1P A (+) |
| 7 | Communication bus | RS485 port 1: RS485-1N B (-) |
| 8 | | Electronic GND |
| 9 | Communication bus | RS485 port 2: RS485 port 2: RS485-2P A (+) active only with optional module |
| 10 | | RS485 port 2: RS485 port 2: RS485-2N B (-) active only with optional module |
| 11 | External Lack of Water | Low water reference |
| 12 | | Low water input |
| 13 | External Start/Stop | External ON/OFF input reference |
| 14 | | External ON/OFF input |
| 15 | External Pressure sensor | External sensor 4-20 mA input |
| 16 | | Power supply external sensor +15 VDC |
| 17 | External Pressure sensor [also Differential] | External sensor 4-20 mA input |
| 18 | | Power supply external sensor +15 VDC |
| 19 | Analog input 0-10V | GND for 0-10 V input |
| 20 | | Actuator mode 0-10 V input |
| 21 | Auxiliary Voltage Supply | Auxiliary voltage supply +15 VDC |
| 22 | Motor running signal | Normally open contact |
| 23 | | Common contact |
| 24 | Fault Signal | NO - error status relay |
| 25 | | COM - error status relay |

MorsT-en_a_sc

VME SERIES
HOW TO READ SMART PUMP SERIES CURVES

To exploit to the maximum potential of Smart Pumps it's important to properly read working curves:

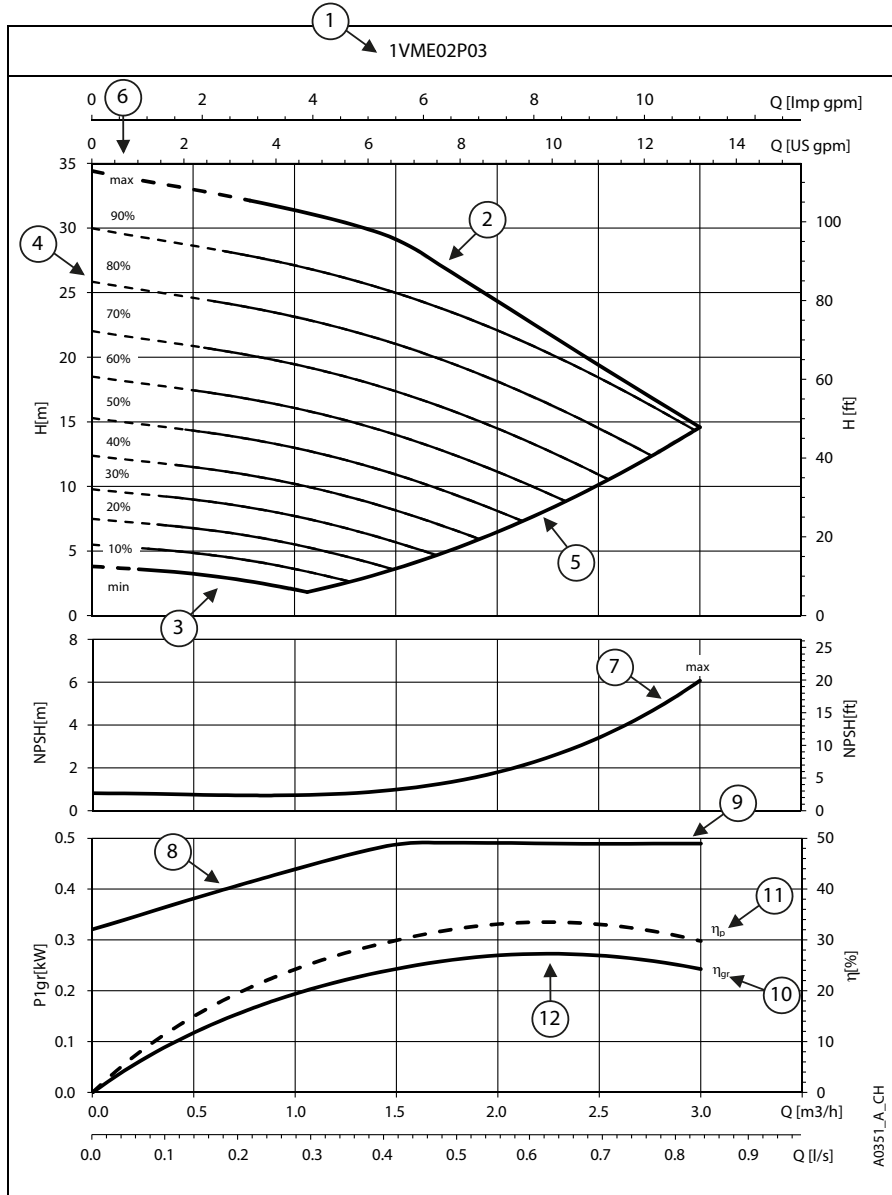

① **Pump model**

② **Maximum curve:** equal to 3600 rpm or pump running at nominal power.

③ **Minimum speed curve:** it refers to the minimum rpm level the motor can work at, it's calculated depending on the model of pump maximizing for each one the working area and allowing the highest system flexibility.

④ The **area with dotted lines** is where the pump can only operate intermittently for short periods of time.

⑤ Each **intermediate curve** between max and min speed shows the percentage of load the pump+motor+drive system is working at; it's easy to read also from the LED speed bar on the HMI keypad: at 90% there will be 9 led, at 80% there will be 8 and so on.

Example: at 60% there will be 6 lit leds

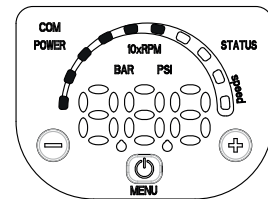

⑥ The **part load percentage** is calculated depending on maximum speed (*max*, 100%) and minimum speed (*min*, equal to 0%, which is the minimum part load step, below it the drive stays powered up but cannot work).

⑦ **NPSH:** is the net positive suction head of pump+motor+drive system working at maximum speed.

⑧ **P1_{gr}** is the power absorption in kW of pump+motor+drive system working at maximum speed.

⑨ **Load control:** the Smart Pump controls and limits power consumption at high flow/low head, in this way the motor stays protected from overload and ensure a longer life of pump+motor+drive system.

⑩ **η_{gr}** is the efficiency of pump+motor+drive system working at maximum speed.

⑪ **η_p** is the efficiency of the hydraulic part, working at maximum speed.

⑫ **Working point:** it's important to make sure the pump is working at the best working point, the one at highest efficiency.

It's easy to find it: it's the highest point of the hp pump efficiency curve; once you found it, you can learn also flow values from x-axis called Q and head values from y-axis called H which allow the system to work at the best working point.

VME SERIES - SINGLE-PHASE VERSION HYDRAULIC PERFORMANCE TABLE

| PUMP TYPE VME Single-phase | MOTOR | | e-SM SET | | Q = DELIVERY | | | | | | | |
|---|----------------------|-----------------|------------------------|-----------------------|---------------------|------|------|------|------|------|------|------|
| | P _N kW | TYPE 1x230 V | * P ₁ kW | * I 208-240 V A | l/min 0 | 6,7 | 13,3 | 20,0 | 26,7 | 33,3 | 40,0 | 50,0 |
| | | | | | m ³ /h 0 | 0,4 | 0,8 | 1,2 | 1,6 | 2,0 | 2,4 | 3,0 |
| H = TOTAL HEAD IN METRES OF COLUMN OF WATER | | | | | | | | | | | | |
| 1VME02P03M02 | 0,37 | ESM80/103 HM.. | 0,49 | 2,24 | 34,4 | 33,3 | 32,1 | 30,6 | 28,3 | 24,4 | 20,4 | 14,6 |
| 1VME04P05M02 | 0,55 | ESM80/105 HM.. | 0,69 | 3,07 | 57,5 | 55,3 | 53,1 | 50,4 | 46,7 | 39,3 | 32,0 | 21,9 |
| 1VME05P07M02 | 0,75 | ESM80/107 HM.. | 0,91 | 4,04 | 80,8 | 78,0 | 75,0 | 71,7 | 63,0 | 53,5 | 44,1 | 30,8 |
| 1VME06P11M02 | 1,1 | ESM80/111 HM.. | 1,33 | 5,85 | 99,8 | 96,3 | 92,8 | 88,5 | 83,2 | 76,1 | 65,5 | 47,9 |

| PUMP TYPE VME Single-phase | MOTOR | | e-SM SET | | Q = DELIVERY | | | | | | | |
|---|----------------------|-----------------|------------------------|-----------------------|---------------------|------|------|------|------|------|------|------|
| | P _N kW | TYPE 1x230 V | * P ₁ kW | * I 208-240 V A | l/min 0 | 13,3 | 26,7 | 40,0 | 53,3 | 66,7 | 80,0 | 86,7 |
| | | | | | m ³ /h 0 | 0,8 | 1,6 | 2,4 | 3,2 | 4,0 | 4,8 | 5,2 |
| H = TOTAL HEAD IN METRES OF COLUMN OF WATER | | | | | | | | | | | | |
| 3VME02P03M02 | 0,37 | ESM80/103 HM.. | 0,49 | 2,24 | 35,5 | 34,3 | 31,2 | 25,0 | 19,5 | 14,5 | 9,8 | 7,5 |
| 3VME03P05M02 | 0,55 | ESM80/105 HM.. | 0,69 | 3,07 | 53,2 | 51,3 | 47,1 | 37,9 | 29,8 | 22,7 | 16,1 | 12,4 |
| 3VME04P07M02 | 0,75 | ESM80/107 HM.. | 0,91 | 4,06 | 70,9 | 68,3 | 63,9 | 51,6 | 40,6 | 31,1 | 22,3 | 17,3 |
| 3VME05P11M02 | 1,1 | ESM80/111 HM.. | 1,33 | 5,85 | 88,6 | 85,5 | 82,4 | 74,3 | 59,5 | 46,6 | 34,8 | 28,8 |
| 3VME06P15M02 | 1,5 | ESM80/115 HM.. | 1,78 | 7,78 | 100,5 | 96,8 | 93,2 | 86,6 | 77,0 | 64,1 | 49,3 | 42,0 |

| PUMP TYPE VME Single-phase | MOTOR | | e-SM SET | | Q = DELIVERY | | | | | | | |
|---|----------------------|-----------------|------------------------|-----------------------|---------------------|------|------|------|------|-------|-------|-------|
| | P _N kW | TYPE 1x230 V | * P ₁ kW | * I 208-240 V A | l/min 0 | 20,0 | 40,0 | 60,0 | 80,0 | 100,0 | 120,0 | 140,0 |
| | | | | | m ³ /h 0 | 1,2 | 2,4 | 3,6 | 4,8 | 6,0 | 7,2 | 8,4 |
| H = TOTAL HEAD IN METRES OF COLUMN OF WATER | | | | | | | | | | | | |
| 5VME02P05M02 | 0,55 | ESM80/105 HM.. | 0,69 | 3,07 | 36,3 | 34,8 | 33,4 | 29,1 | 23,4 | 18,7 | 14,1 | 8,9 |
| 5VME03P07M02 | 0,75 | ESM80/107 HM.. | 0,92 | 4,06 | 54,2 | 52,4 | 49,8 | 39,9 | 32,5 | 25,8 | 18,8 | 11,5 |
| 5VME04P11M02 | 1,1 | ESM80/111 HM.. | 1,33 | 5,85 | 72,3 | 69,9 | 66,3 | 57,8 | 47,4 | 38,2 | 28,6 | 18,6 |
| 5VME05P15M02 | 1,5 | ESM80/115 HM.. | 1,78 | 7,80 | 90,4 | 87,4 | 82,9 | 77,9 | 64,2 | 52,3 | 40,1 | 27,3 |

| PUMP TYPE VME Single-phase | MOTOR | | e-SM SET | | Q = DELIVERY | | | | | | | |
|---|----------------------|-----------------|------------------------|-----------------------|---------------------|------|------|-------|-------|-------|-------|-------|
| | P _N kW | TYPE 1x230 V | * P ₁ kW | * I 208-240 V A | l/min 0 | 40,0 | 80,0 | 120,0 | 160,0 | 200,0 | 240,0 | 283,3 |
| | | | | | m ³ /h 0 | 2,4 | 4,8 | 7,2 | 9,6 | 12,0 | 14,4 | 17,0 |
| H = TOTAL HEAD IN METRES OF COLUMN OF WATER | | | | | | | | | | | | |
| 10VME01P07M02 | 0,75 | ESM80/107 HM.. | 0,91 | 4,04 | 22,6 | 22,2 | 21,2 | 20,0 | 16,6 | 13,5 | 10,4 | 6,8 |
| 10VME02P11M02 | 1,1 | ESM80/111 HM.. | 1,34 | 5,86 | 38,0 | 37,2 | 35,4 | 30,7 | 24,7 | 19,2 | 13,4 | 6,7 |

* Maximum value in specified range: P₁ = input power; I = input current.

1-10vme-esm-2p50-en_a_th

ELECTRICAL DATA TABLE

| P _N kW | MOTOR TYPE | IEC SIZE | Construction Design | SPEED (RPM)* min ⁻¹ | INPUT CURRENT I (A) 208-240 V | DATA RELATED TO THE VOLTAGE OF 230V | | | | | | |
|----------------------|----------------|----------|------------------------|--------------------------------------|-------------------------------------|-------------------------------------|------|----------|--------------------|------|------|-----|
| | | | | | | In A | cosφ | Tn Nm | η % 4/4 3/4 2/4 | | | IES |
| 0,37 | ESM80/103 HM.. | 80 | SPECIAL | 3000 | 2,28-1,99 | 2,08 | 0,95 | 1,18 | 81,3 | 79,1 | 74,3 | 2 |
| | | | | 3600 | 2,30-2,02 | 2,10 | | 0,98 | 80,6 | 77,5 | 72,0 | |
| 0,55 | ESM80/105 HM.. | 80 | | 3000 | 3,27-2,85 | 2,96 | 0,97 | 1,75 | 83,3 | 82,2 | 78,8 | 2 |
| | | | | 3600 | 3,27-2,85 | 2,96 | | 1,46 | 83,3 | 81,5 | 77,5 | |
| 0,75 | ESM80/107 HM.. | 80 | | 3000 | 4,43-3,84 | 4,00 | 0,98 | 2,39 | 83,3 | 83,3 | 81,5 | 2 |
| | | | | 3600 | 4,38-3,79 | 3,94 | | 1,99 | 84,5 | 83,5 | 80,6 | |
| 1,10 | ESM80/111 HM.. | 80 | | 3000 | 6,26-5,35 | 5,64 | 0,99 | 3,50 | 85,7 | 85,1 | 82,7 | 2 |
| | | | | 3600 | 6,20-5,32 | 5,63 | | 2,92 | 85,9 | 84,6 | 81,4 | |
| 1,50 | ESM80/115 HM.. | 80 | | 3000 | 8,57-7,32 | 7,69 | 0,99 | 4,77 | 85,6 | 85,7 | 84,7 | 2 |
| | | | | 3600 | 8,42-7,25 | 7,62 | | 3,98 | 86,3 | 85,9 | 84,0 | |

* The indicated rotational speed are representing the upper and lower limits of the rated power operational speed range.

eHM-eVM_Smart-motm_en_a_te

The nominal motor power is guaranteed in the 3000-3600 rpm range. The motor is automatically limited to 3600 rpm maximum; the motor works partially loaded below 3000 rpm.

VME SERIES - THREE-PHASE VERSION HYDRAULIC PERFORMANCE TABLE

| PUMP TYPE VME Three-phase | MOTOR | | e-SM SET | | Q = DELIVERY | | | | | | | | |
|------------------------------------|----------------------|----------------|------------------------|-----------|--------------|---------------------|------|------|------|------|------|------|------|
| | P _N kW | TYPE | * P ₁ kW | * I | * I | l/min 0 | 6,7 | 13,3 | 20,0 | 26,7 | 33,3 | 40,0 | 50,0 |
| | | | | 208-240 V | 380-460 V | m ³ /h 0 | 0,4 | 0,8 | 1,2 | 1,6 | 2,0 | 2,4 | 3,0 |
| 1VME02P03T.. | 0,37 | ESM80/303 HM.. | 0,49 | 2,14 | 1,45 | 34,4 | 33,3 | 32,1 | 30,6 | 28,4 | 24,4 | 20,5 | 14,6 |
| 1VME04P05T.. | 0,55 | ESM80/305 HM.. | 0,69 | 2,77 | 1,92 | 57,5 | 55,3 | 53,1 | 50,4 | 46,7 | 39,4 | 32,1 | 21,9 |
| 1VME05P07T.. | 0,75 | ESM80/307 HM.. | 0,91 | 3,55 | 2,41 | 80,8 | 78,0 | 75,0 | 71,7 | 63,0 | 53,5 | 44,1 | 30,8 |
| 1VME06P11T.. | 1,1 | ESM80/311 HM.. | 1,37 | 4,92 | 3,44 | 99,8 | 96,3 | 92,8 | 88,5 | 83,2 | 76,1 | 65,4 | 47,9 |

| PUMP TYPE VME Three-phase | MOTOR | | e-SM SET | | Q = DELIVERY | | | | | | | | |
|------------------------------------|----------------------|----------------|------------------------|-----------|--------------|---------------------|------|------|------|------|------|------|------|
| | P _N kW | TYPE | * P ₁ kW | * I | * I | l/min 0 | 13,3 | 26,7 | 40,0 | 53,3 | 66,7 | 80,0 | 86,7 |
| | | | | 208-240 V | 380-460 V | m ³ /h 0 | 0,8 | 1,6 | 2,4 | 3,2 | 4,0 | 4,8 | 5,2 |
| 3VME02P03T.. | 0,37 | ESM80/303 HM.. | 0,50 | 2,13 | 1,48 | 35,5 | 34,3 | 31,2 | 25,1 | 19,5 | 14,5 | 9,8 | 7,5 |
| 3VME03P05T.. | 0,55 | ESM80/305 HM.. | 0,70 | 2,81 | 1,92 | 53,2 | 51,3 | 47,1 | 37,9 | 29,8 | 22,7 | 16,1 | 12,4 |
| 3VME04P07T.. | 0,75 | ESM80/307 HM.. | 0,92 | 3,55 | 2,43 | 70,9 | 68,3 | 64,0 | 51,6 | 40,6 | 31,1 | 22,3 | 17,3 |
| 3VME05P11T.. | 1,1 | ESM80/311 HM.. | 1,37 | 4,94 | 3,45 | 88,6 | 85,5 | 82,4 | 74,2 | 59,4 | 46,5 | 34,9 | 28,8 |
| 3VME06P15T.. | 1,5 | ESM80/315 HM.. | 1,81 | 6,32 | 4,40 | 100,5 | 96,8 | 93,2 | 86,6 | 77,0 | 64,1 | 49,3 | 42,0 |

| PUMP TYPE VME Three-phase | MOTOR | | e-SM SET | | Q = DELIVERY | | | | | | | | |
|------------------------------------|----------------------|----------------|------------------------|-----------|--------------|---------------------|------|------|------|------|-------|-------|-------|
| | P _N kW | TYPE | * P ₁ kW | * I | * I | l/min 0 | 20,0 | 40,0 | 60,0 | 80,0 | 100,0 | 120,0 | 140,0 |
| | | | | 208-240 V | 380-460 V | m ³ /h 0 | 1,2 | 2,4 | 3,6 | 4,8 | 6,0 | 7,2 | 8,4 |
| 5VME02P05T.. | 0,55 | ESM80/305 HM.. | 0,69 | 2,81 | 1,91 | 36,3 | 34,8 | 33,4 | 29,1 | 23,5 | 18,7 | 14,1 | 8,9 |
| 5VME03P07T.. | 0,75 | ESM80/307 HM.. | 0,92 | 3,55 | 2,43 | 54,2 | 52,4 | 49,8 | 39,9 | 32,5 | 25,8 | 18,8 | 11,5 |
| 5VME04P11T.. | 1,1 | ESM80/311 HM.. | 1,37 | 4,95 | 3,45 | 72,3 | 69,9 | 66,3 | 57,8 | 47,4 | 38,2 | 28,6 | 18,6 |
| 5VME05P15T.. | 1,5 | ESM80/315 HM.. | 1,82 | 6,35 | 4,42 | 90,4 | 87,4 | 82,9 | 78,0 | 64,2 | 52,3 | 40,1 | 27,3 |
| 5VME06P22T04 | 2,2 | ESM80/322 HM.. | 2,33 | - | 5,44 | 99,6 | 96,1 | 90,9 | 85,3 | 78,6 | 69,2 | 55,6 | 37,2 |

| PUMP TYPE VME Three-phase | MOTOR | | e-SM SET | | Q = DELIVERY | | | | | | | | |
|------------------------------------|----------------------|----------------|------------------------|-----------|--------------|---------------------|------|------|-------|-------|-------|-------|-------|
| | P _N kW | TYPE | * P ₁ kW | * I | * I | l/min 0 | 40,0 | 80,0 | 120,0 | 160,0 | 200,0 | 240,0 | 283,3 |
| | | | | 208-240 V | 380-460 V | m ³ /h 0 | 2,4 | 4,8 | 7,2 | 9,6 | 12,0 | 14,4 | 17,0 |
| 10VME01P07T.. | 0,75 | ESM80/307 HM.. | 0,91 | 3,55 | 2,40 | 22,6 | 22,2 | 21,2 | 20,0 | 16,6 | 13,5 | 10,4 | 6,8 |
| 10VME02P11T.. | 1,1 | ESM80/311 HM.. | 1,38 | 5,00 | 3,47 | 38,0 | 37,2 | 35,4 | 30,7 | 24,7 | 19,2 | 13,4 | 6,7 |

* Maximum value in specified range: P₁ = input power; I = input current.

1-10vme-esmT-2p50-en_a_te

ELECTRICAL DATA TABLE

| P _N kW | MOTOR TYPE | IEC SIZE | Construction Design | SPEED (RPM) * min ⁻¹ | INPUT CURRENT I (A) 208-240/380-460 V | DATA RELATED TO THE VOLTAGE OF 400 V | | | | | | IES |
|----------------------|----------------|----------|---------------------|------------------------------------|---|--------------------------------------|------|----------------------|------|------|------|-----|
| | | | | | | I _n A | cosφ | T _n Nm | η % | | | |
| | | | | | | | | | 4/4 | 3/4 | 2/4 | |
| 0,37 | ESM80/303 HM.. | 80 | SPECIAL | 3000 | 2,01-1,85/1,41-1,28 | 1,42 | 0,48 | 1,18 | 78,6 | 75,6 | 70,1 | 2 |
| | | | | 3600 | 2,13-1,83/1,43-1,33 | 1,36 | | 0,98 | 83,1 | 80,7 | 76,1 | |
| 0,55 | ESM80/305 HM.. | 80 | | 3000 | 2,81-2,57/1,89-1,69 | 1,88 | 0,52 | 1,75 | 81,1 | 79,3 | 75,5 | 2 |
| | | | | 3600 | 2,90-2,52/1,90-1,73 | 1,80 | | 1,46 | 85,4 | 83,8 | 80,6 | |
| 0,75 | ESM80/307 HM.. | 80 | | 3000 | 3,70-3,37/2,44-2,17 | 2,41 | 0,55 | 2,39 | 81,9 | 81,2 | 78,6 | 2 |
| | | | | 3600 | 3,74-3,28/2,43-2,20 | 2,31 | | 1,99 | 86,1 | 85,5 | 83,1 | |
| 1,10 | ESM80/311 HM.. | 80 | | 3000 | 5,12-4,73/3,41-3,01 | 3,35 | 0,57 | 3,50 | 82,8 | 81,3 | 77,7 | 2 |
| | | | | 3600 | 5,15-4,69/3,45-3,06 | 3,32 | | 2,92 | 83,5 | 81,6 | 77,6 | |
| 1,50 | ESM80/315 HM.. | 80 | | 3000 | 6,73-6,17/4,49-3,95 | 4,39 | 0,59 | 4,77 | 83,1 | 82,8 | 80,6 | 2 |
| | | | | 3600 | 6,69-6,08/4,48-3,97 | 4,32 | | 3,98 | 84,6 | 83,6 | 80,8 | |
| 2,20 | ESM80/322 HM.. | 80 | 3000 | - /6,03-5,32 | 5,81 | 0,62 | 7,00 | 87,6 | 87,4 | 85,9 | 2 | |
| | | | 3600 | - /5,93-5,24 | 5,74 | | 5,84 | 88,9 | 88,2 | 86,3 | | |

* The indicated rotational speed are representing the upper and lower limits of the rated power operational speed range.

eHM-eVM_Smart-mott-en_a_te

The nominal motor power is guaranteed in the 3000-3600 rpm range. The motor is automatically limited to 3600 rpm maximum; the motor works partially loaded below 3000 rpm.

1, 3, 5VME SERIES - SINGLE-PHASE VERSION DIMENSIONS AND WEIGHTS

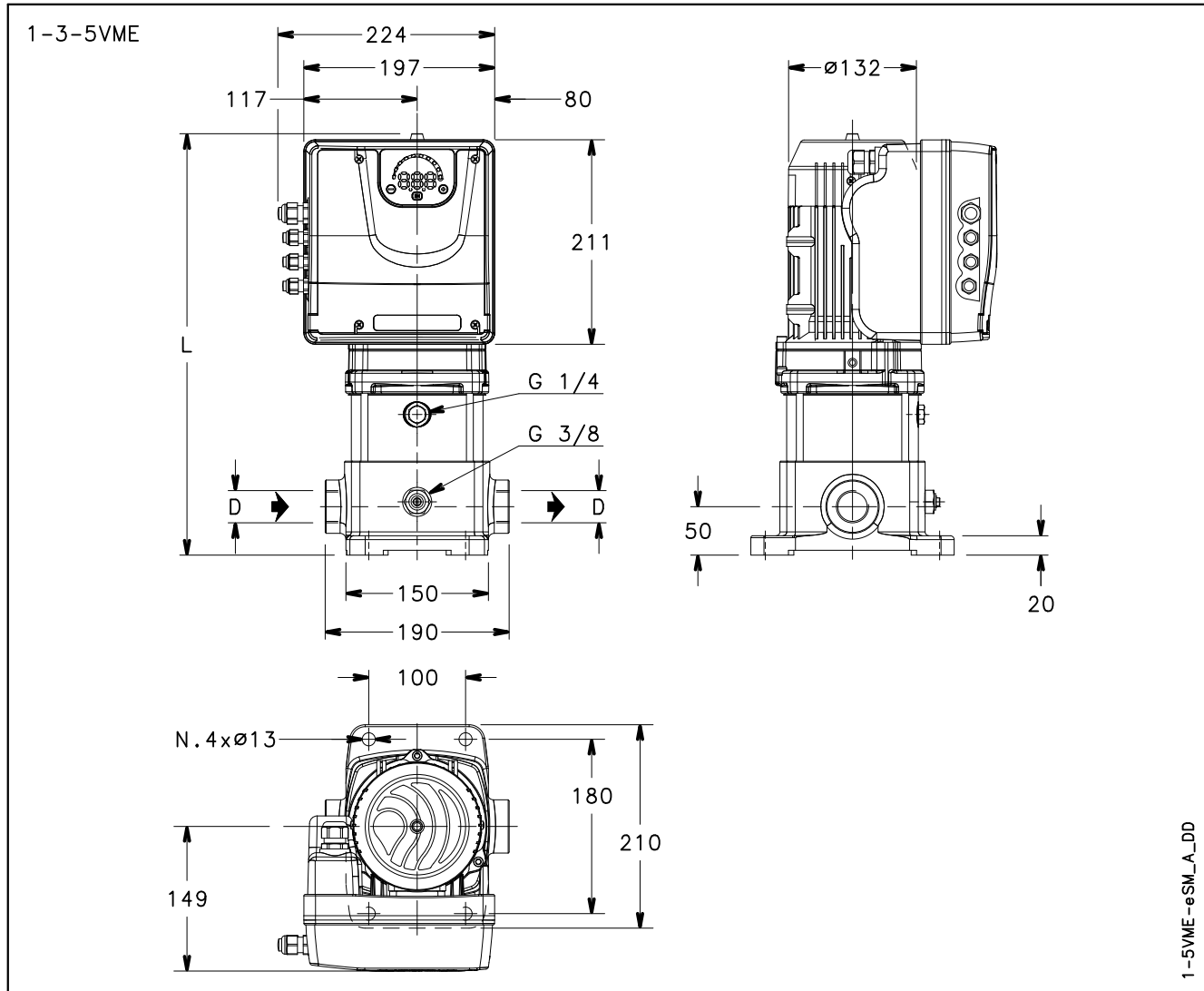

1-5VME-eSM_A_DD

| PUMP TYPE | VERSION | MOTOR | | DIMENSIONS (mm) | | PN bar | WEIGHT kg |
|--------------|--------------|-------|------|-----------------|-----|--------|-----------|
| | | kW | SIZE | D | L | | |
| 1VME02P03M02 | SINGLE-PHASE | 0,37 | 80 | Rp 1 | 415 | 10 | 14,8 |
| 1VME04P05M02 | | 0,55 | 80 | Rp 1 | 435 | 10 | 15,3 |
| 1VME05P07M02 | | 0,75 | 80 | Rp 1 | 455 | 10 | 15,6 |
| 1VME06P11M02 | | 1,1 | 80 | Rp 1 | 475 | 16 | 17,3 |
| 3VME02P03M02 | | 0,37 | 80 | Rp 1 | 415 | 10 | 14,8 |
| 3VME03P05M02 | | 0,55 | 80 | Rp 1 | 415 | 10 | 14,9 |
| 3VME04P07M02 | | 0,75 | 80 | Rp 1 | 435 | 10 | 15,3 |
| 3VME05P11M02 | | 1,1 | 80 | Rp 1 | 455 | 10 | 17,0 |
| 3VME06P15M02 | | 1,5 | 80 | Rp 1 | 475 | 16 | 17,5 |
| 5VME02P05M02 | | 0,55 | 80 | Rp 1 1/4 | 415 | 10 | 14,8 |
| 5VME03P07M02 | | 0,75 | 80 | Rp 1 1/4 | 415 | 10 | 14,9 |
| 5VME04P11M02 | | 1,10 | 80 | Rp 1 1/4 | 435 | 10 | 16,6 |
| 5VME05P15M02 | | 1,5 | 80 | Rp 1 1/4 | 455 | 10 | 17,0 |

1-5vme-esm-2p50-en_a_td

1, 3, 5VME SERIES - THREE-PHASE VERSION DIMENSIONS AND WEIGHTS

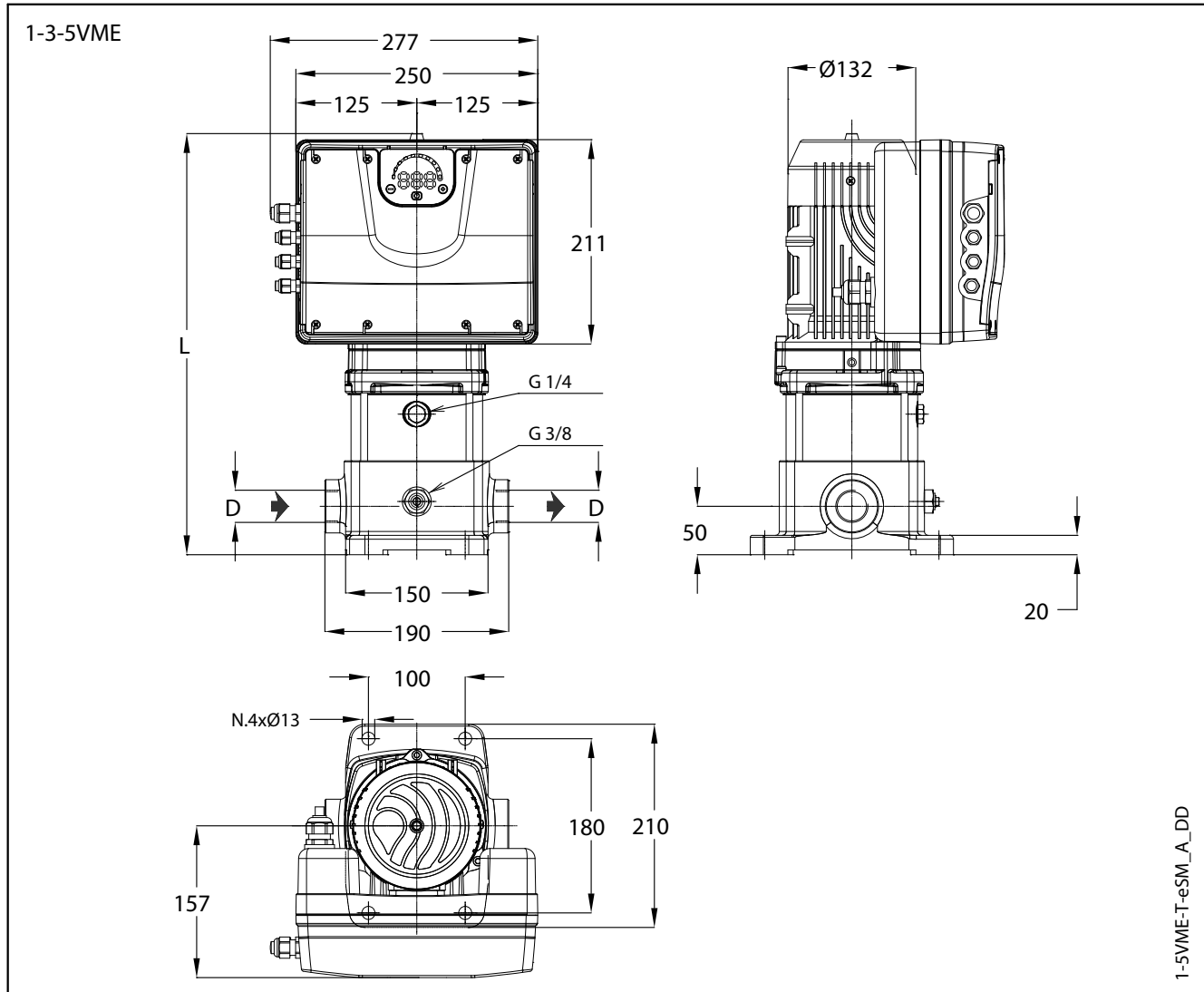

1-5VME-T-esm_A_DD

| PUMP TYPE | VERSION | MOTOR | | DIMENSIONS (mm) | | PN bar | WEIGHT kg |
|--------------|-------------|-------|------|-----------------|-----|--------|-----------|
| | | kw | SIZE | D | L | | |
| 1VME02P03T.. | THREE-PHASE | 0,37 | 80 | Rp 1 | 415 | 10 | 21,7 |
| 1VME04P05T.. | | 0,55 | 80 | Rp 1 | 435 | 10 | 23,0 |
| 1VME05P07T.. | | 0,75 | 80 | Rp 1 | 455 | 10 | 24,0 |
| 1VME06P11T.. | | 1,1 | 80 | Rp 1 | 475 | 16 | 26,5 |
| 3VME02P03T.. | | 0,37 | 80 | Rp 1 | 415 | 10 | 21,7 |
| 3VME03P05T.. | | 0,55 | 80 | Rp 1 | 415 | 10 | 22,0 |
| 3VME04P07T.. | | 0,75 | 80 | Rp 1 | 435 | 10 | 23,0 |
| 3VME05P11T.. | | 1,1 | 80 | Rp 1 | 455 | 10 | 25,5 |
| 3VME06P15T.. | | 1,5 | 80 | Rp 1 | 475 | 16 | 26,8 |
| 5VME02P05T.. | | 0,55 | 80 | Rp 1 1/4 | 415 | 10 | 21,0 |
| 5VME03P07T.. | | 0,75 | 80 | Rp 1 1/4 | 415 | 10 | 21,2 |
| 5VME04P11T.. | | 1,1 | 80 | Rp 1 1/4 | 435 | 10 | 22,2 |
| 5VME05P15T.. | | 1,5 | 80 | Rp 1 1/4 | 455 | 10 | 22,5 |
| 5VME06P22T04 | | 1,5 | 80 | Rp 1 1/4 | 475 | 10 | 24,2 |

1-5vme-esm-2p50T-en_a_td

**1VME SERIES
OPERATING CHARACTERISTICS**

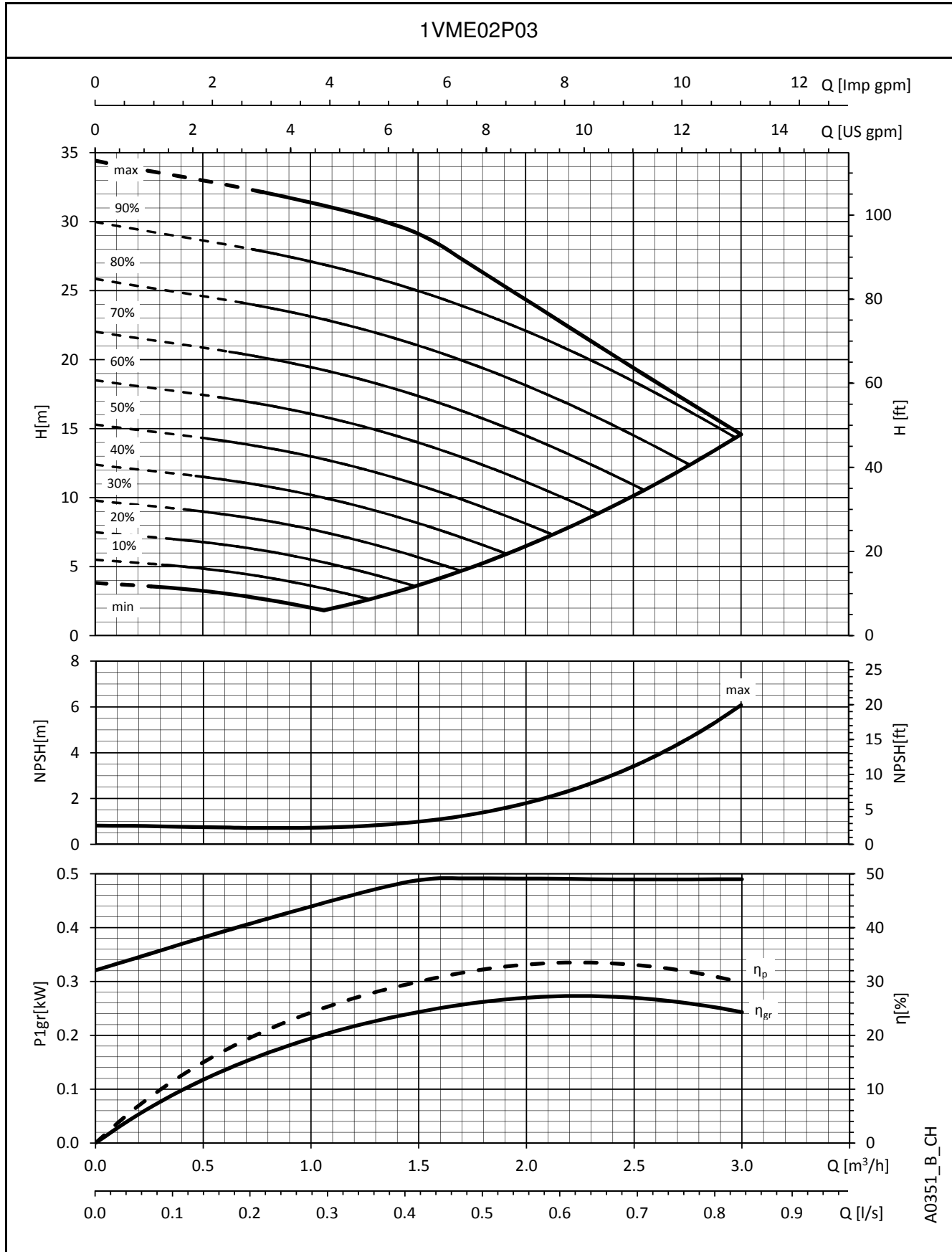

The performances are valid for liquid with density $\rho = 1 \text{ Kg/dm}^3$ and kinematic viscosity $\nu = 1 \text{ mm}^2/\text{sec}$.

1VME SERIES OPERATING CHARACTERISTICS

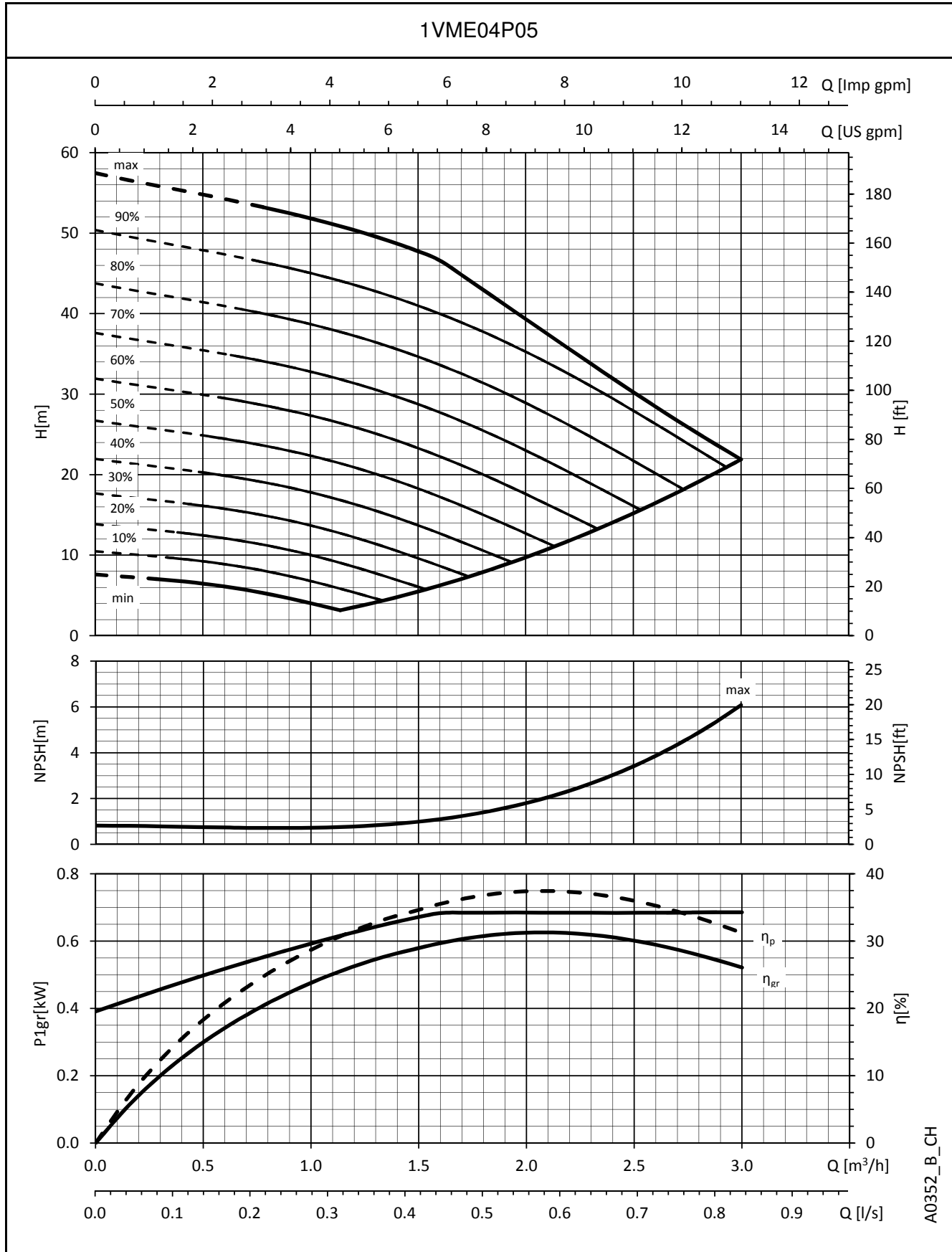

A0352_B_CH

The performances are valid for liquid with density $\rho = 1 \text{ Kg/dm}^3$ and kinematic viscosity $\nu = 1 \text{ mm}^2/\text{sec}$.

**1VME SERIES
OPERATING CHARACTERISTICS**

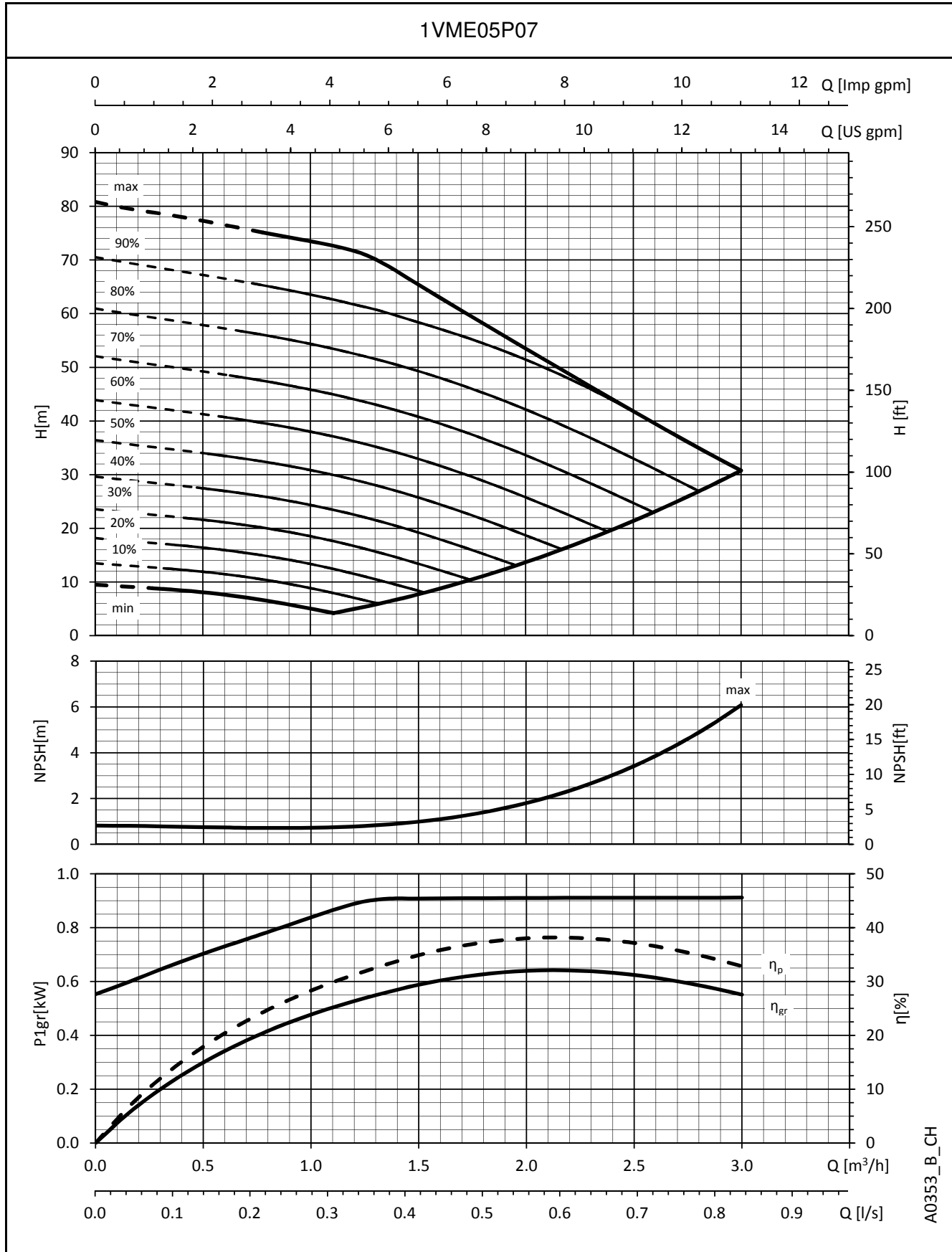

The performances are valid for liquid with density $\rho = 1 \text{ Kg/dm}^3$ and kinematic viscosity $\nu = 1 \text{ mm}^2/\text{sec}$.

**1VME SERIES
OPERATING CHARACTERISTICS**

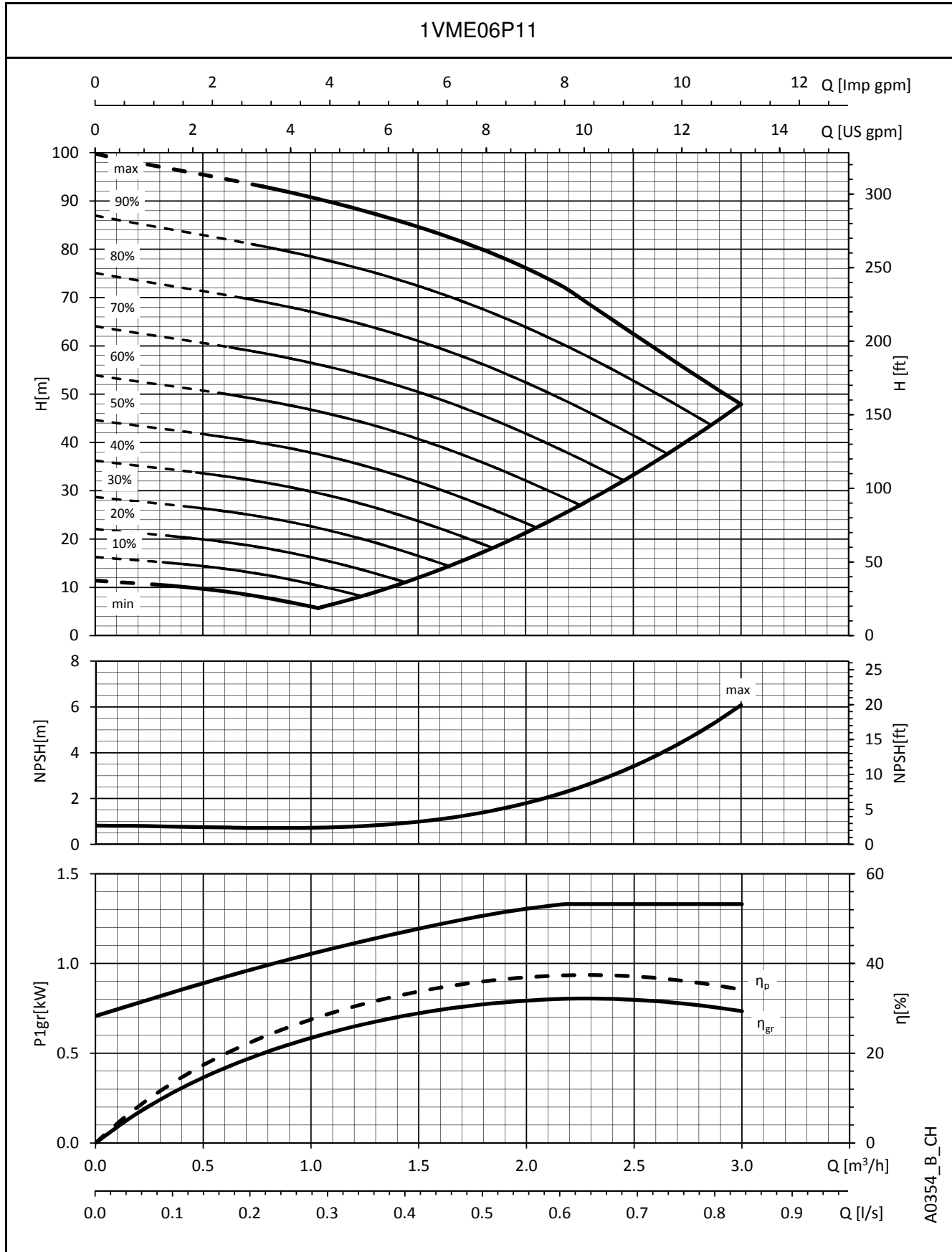

The performances are valid for liquid with density $\rho = 1 \text{ Kg/dm}^3$ and kinematic viscosity $\nu = 1 \text{ mm}^2/\text{sec}$.

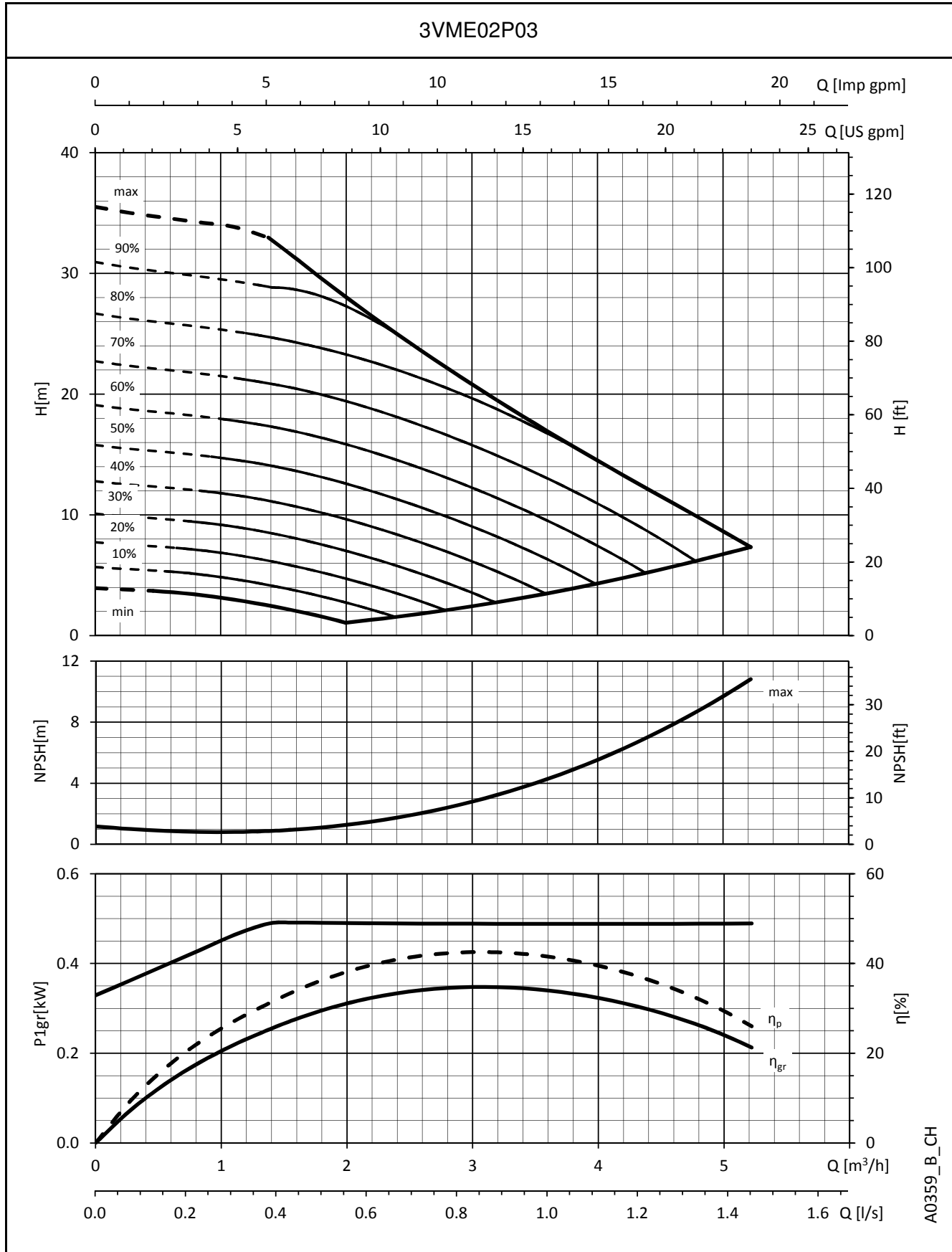
**3VME SERIES
OPERATING CHARACTERISTICS**

A0359_B_CH

 The performances are valid for liquid with density $\rho = 1 \text{ Kg/dm}^3$ and kinematic viscosity $\nu = 1 \text{ mm}^2/\text{sec}$.

3VME SERIES OPERATING CHARACTERISTICS

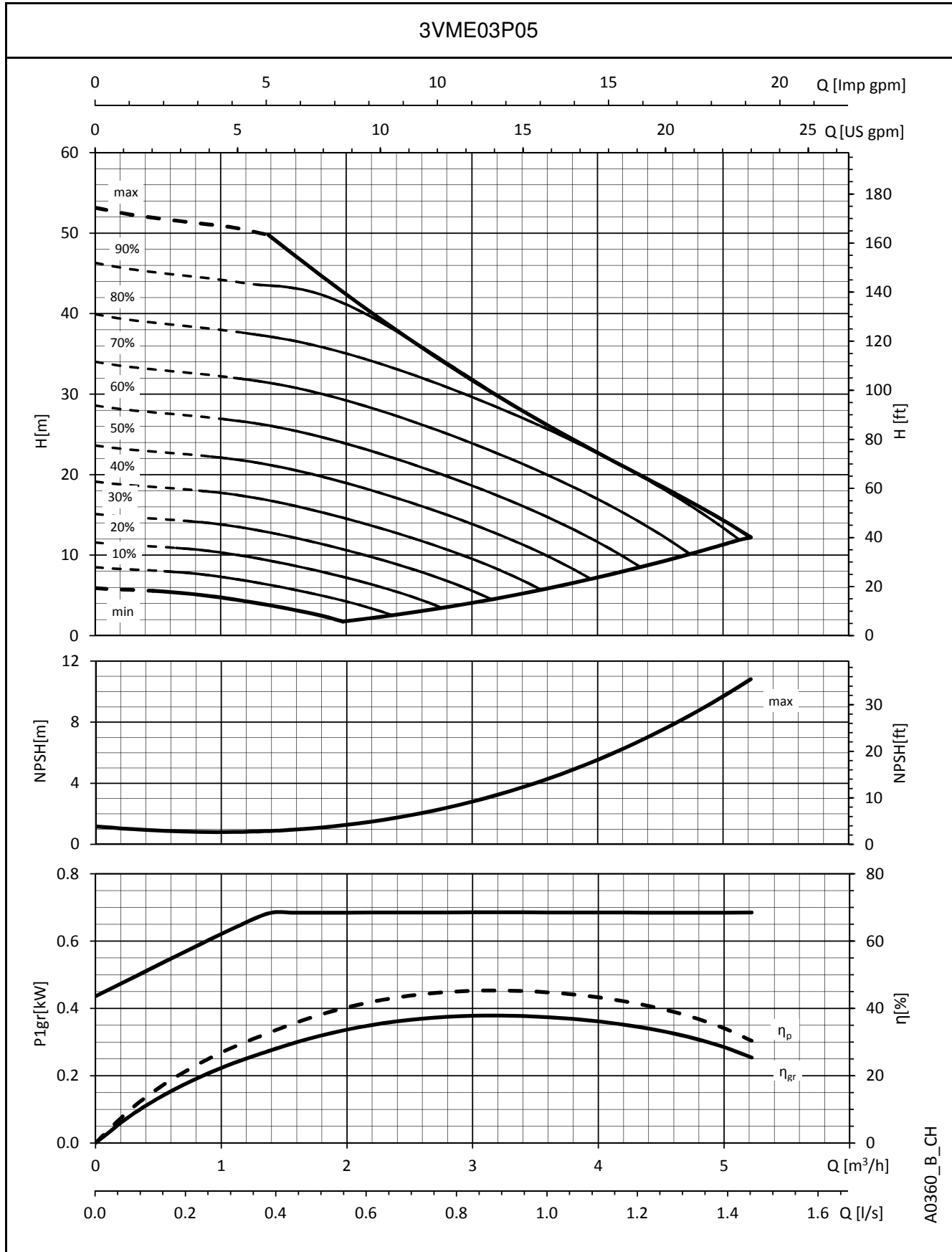

A0360_B_CH

The performances are valid for liquid with density $\rho = 1 \text{ Kg/dm}^3$ and kinematic viscosity $\nu = 1 \text{ mm}^2/\text{sec}$.

**3VME SERIES
OPERATING CHARACTERISTICS**

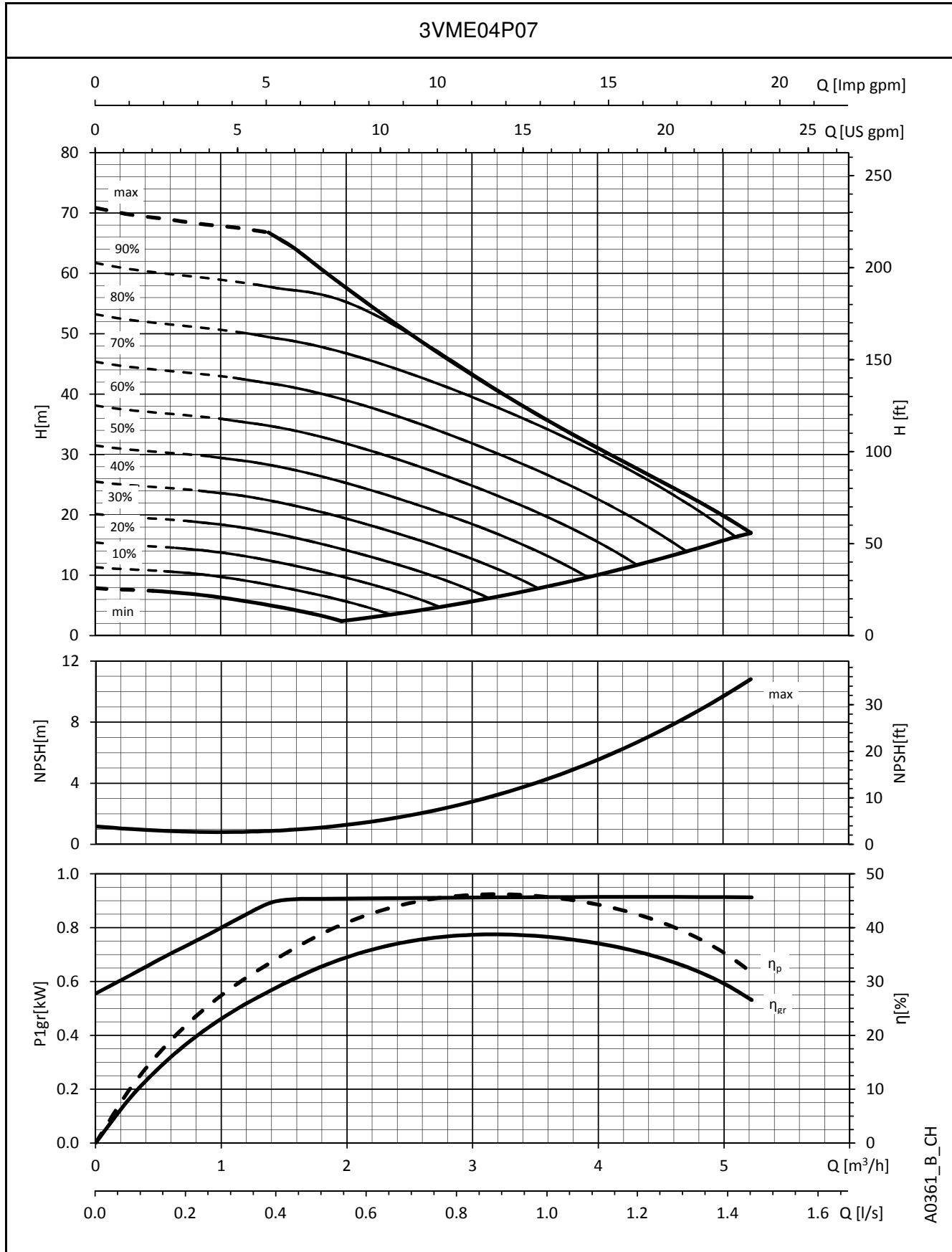

The performances are valid for liquid with density $\rho = 1 \text{ Kg/dm}^3$ and kinematic viscosity $\nu = 1 \text{ mm}^2/\text{sec}$.

A0361_B_CH

**3VME SERIES
OPERATING CHARACTERISTICS**

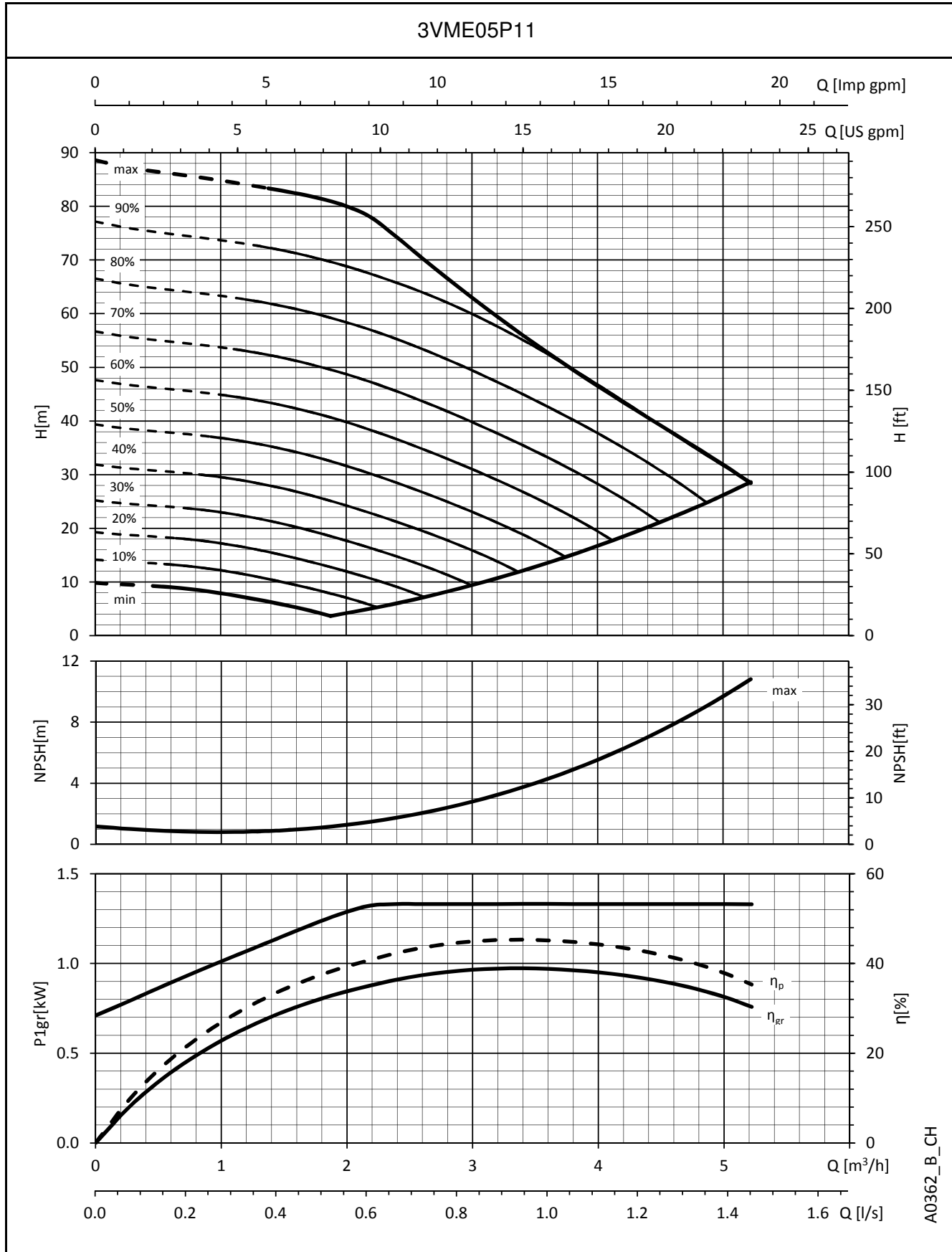

A0362_B_CH

The performances are valid for liquid with density $\rho = 1 \text{ Kg/dm}^3$ and kinematic viscosity $\nu = 1 \text{ mm}^2/\text{sec}$.

**3VME SERIES
OPERATING CHARACTERISTICS**

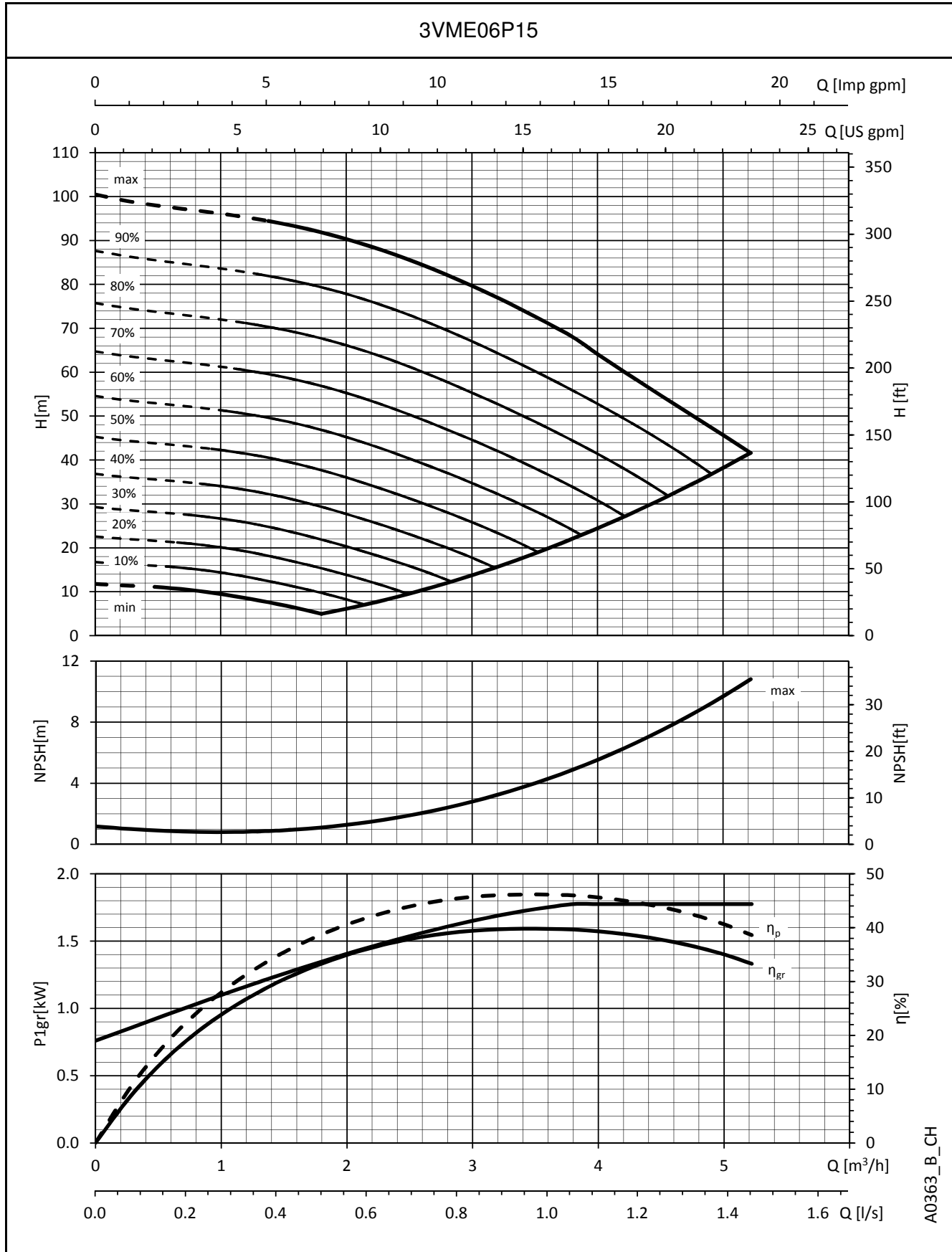

The performances are valid for liquid with density $\rho = 1 \text{ Kg/dm}^3$ and kinematic viscosity $\nu = 1 \text{ mm}^2/\text{sec}$.

A0363_B_CH

**5VME SERIES
OPERATING CHARACTERISTICS**

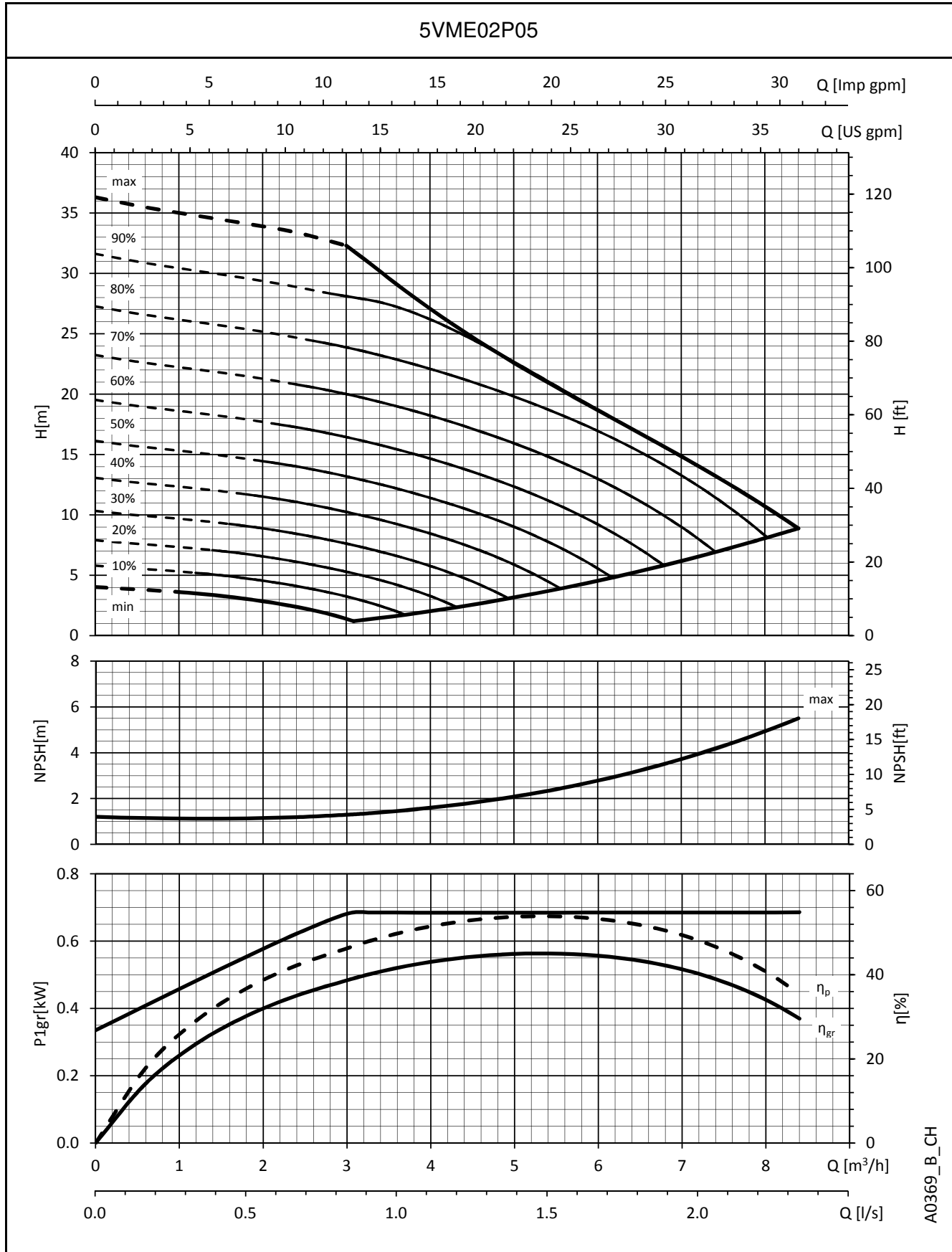

A0369_B_CH

The performances are valid for liquid with density $\rho = 1 \text{ Kg/dm}^3$ and kinematic viscosity $\nu = 1 \text{ mm}^2/\text{sec}$.

**5VME SERIES
OPERATING CHARACTERISTICS**

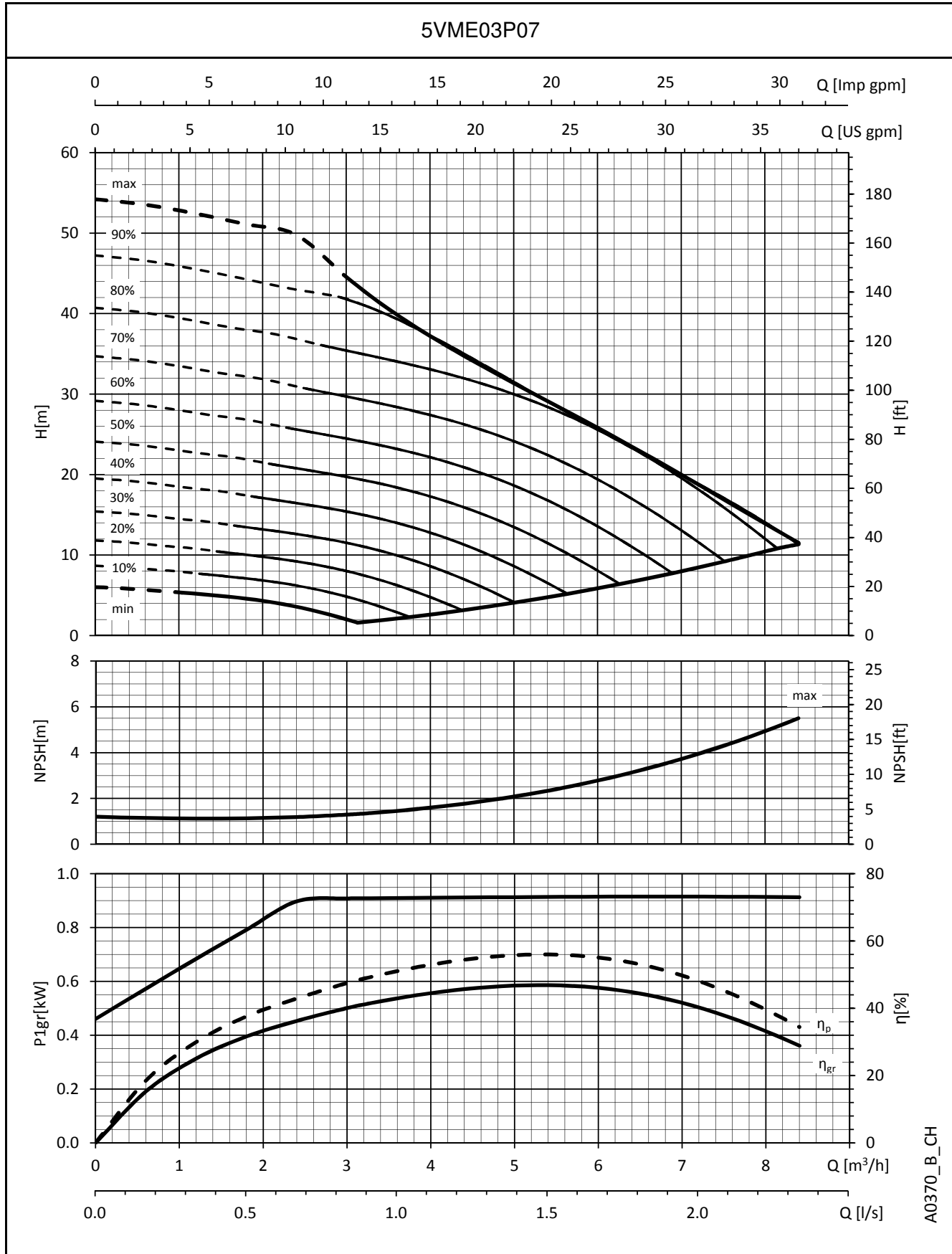

The performances are valid for liquid with density $\rho = 1 \text{ Kg/dm}^3$ and kinematic viscosity $\nu = 1 \text{ mm}^2/\text{sec}$.

**5VME SERIES
OPERATING CHARACTERISTICS**

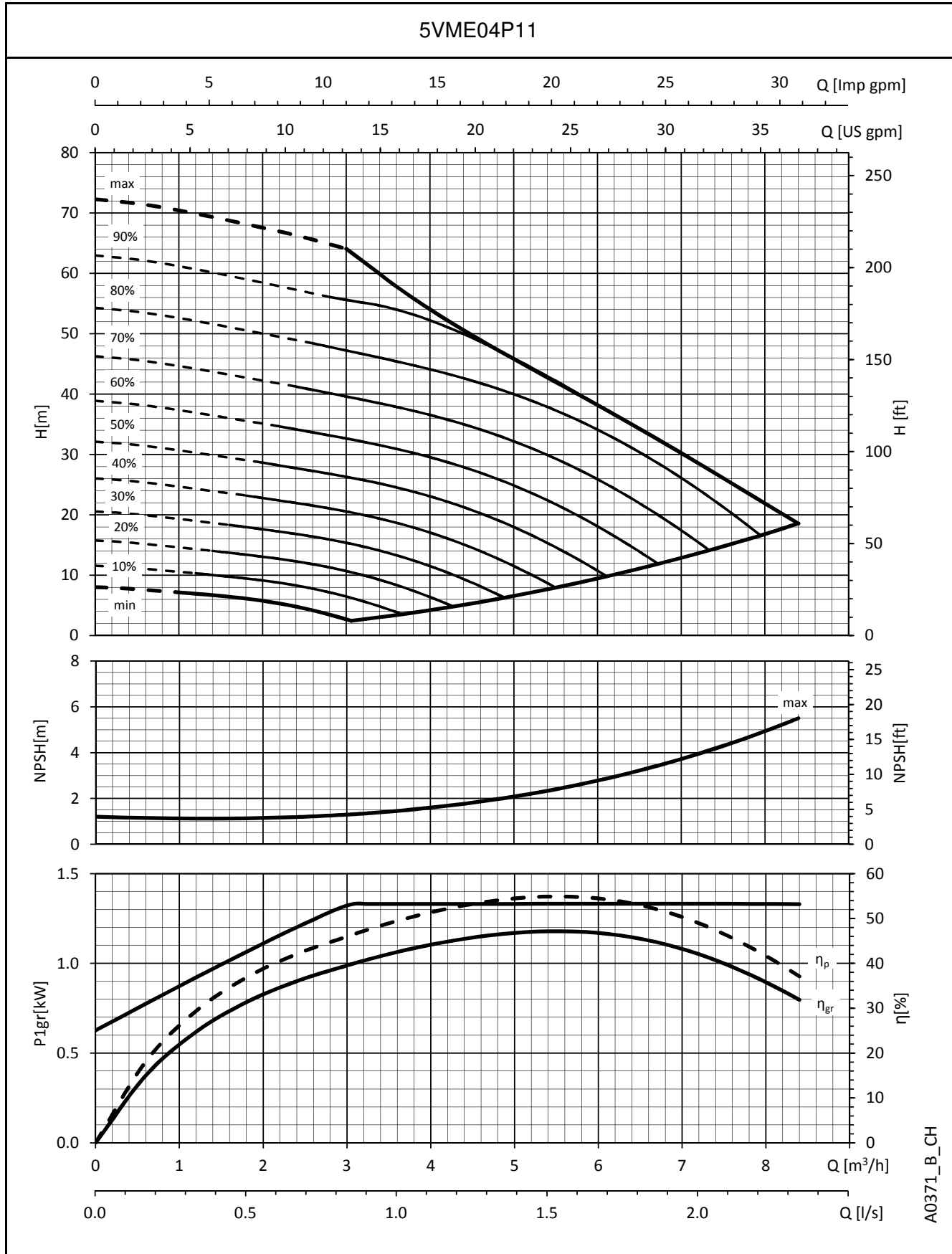

The performances are valid for liquid with density $\rho = 1 \text{ Kg/dm}^3$ and kinematic viscosity $\nu = 1 \text{ mm}^2/\text{sec}$.

**5VME SERIES
OPERATING CHARACTERISTICS**

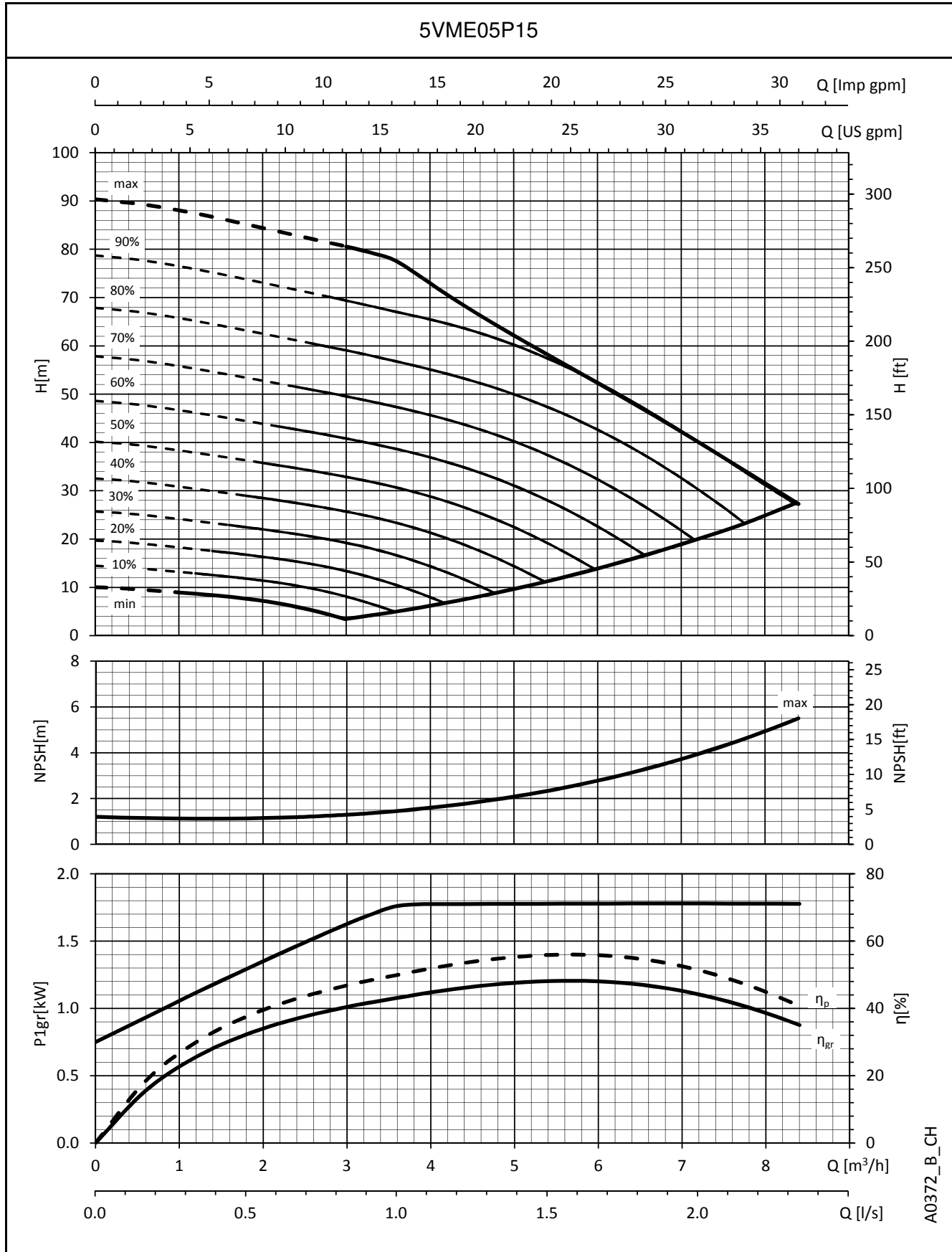

A0372_B_CH

The performances are valid for liquid with density $\rho = 1 \text{ Kg/dm}^3$ and kinematic viscosity $\nu = 1 \text{ mm}^2/\text{sec}$.

**5VME SERIES
OPERATING CHARACTERISTICS**

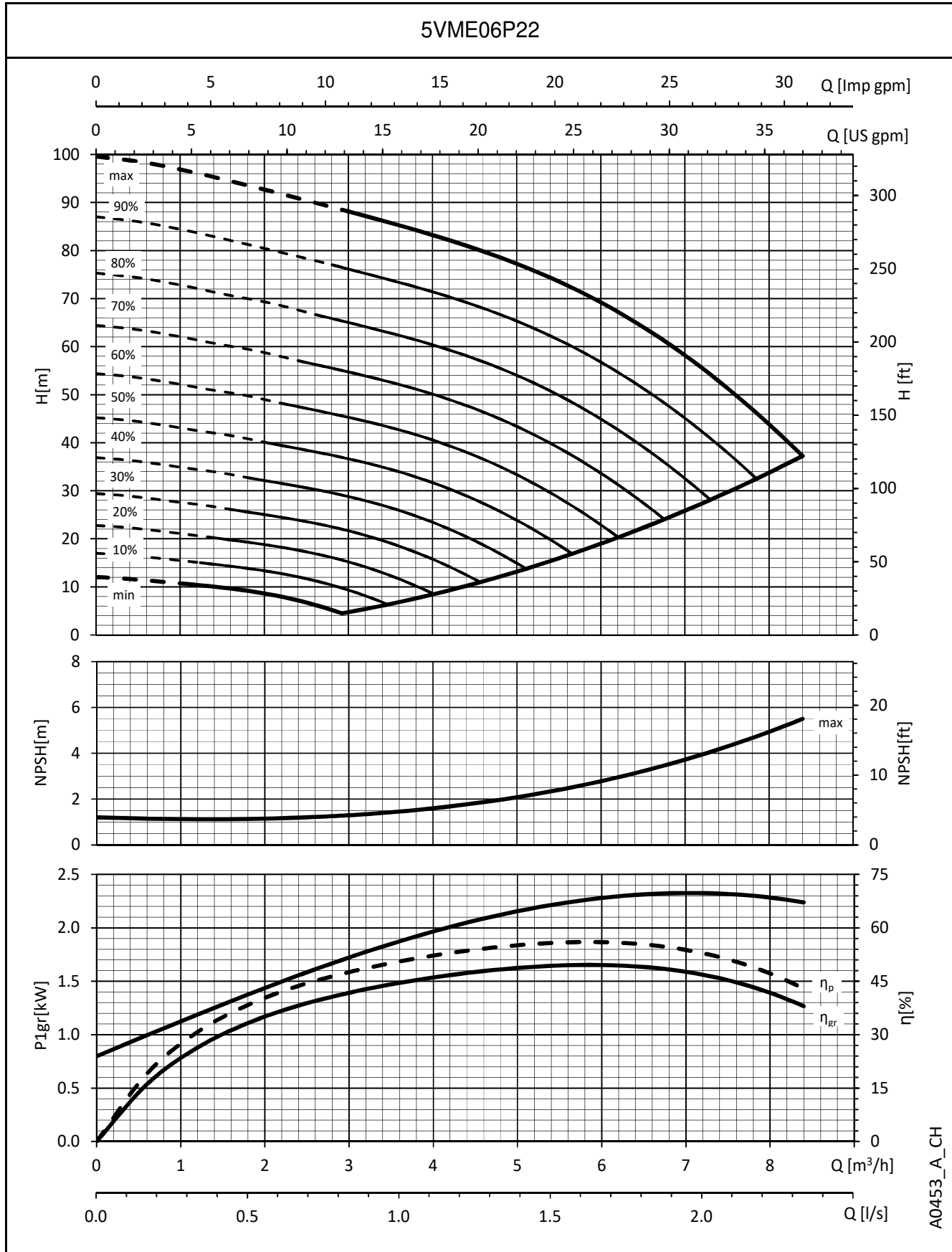

A0453_A_CH

The performances are valid for liquid with density $\rho = 1 \text{ Kg/dm}^3$ and kinematic viscosity $\nu = 1 \text{ mm}^2/\text{sec}$.

10VME SERIES - SINGLE-PHASE VERSION DIMENSIONS AND WEIGHTS

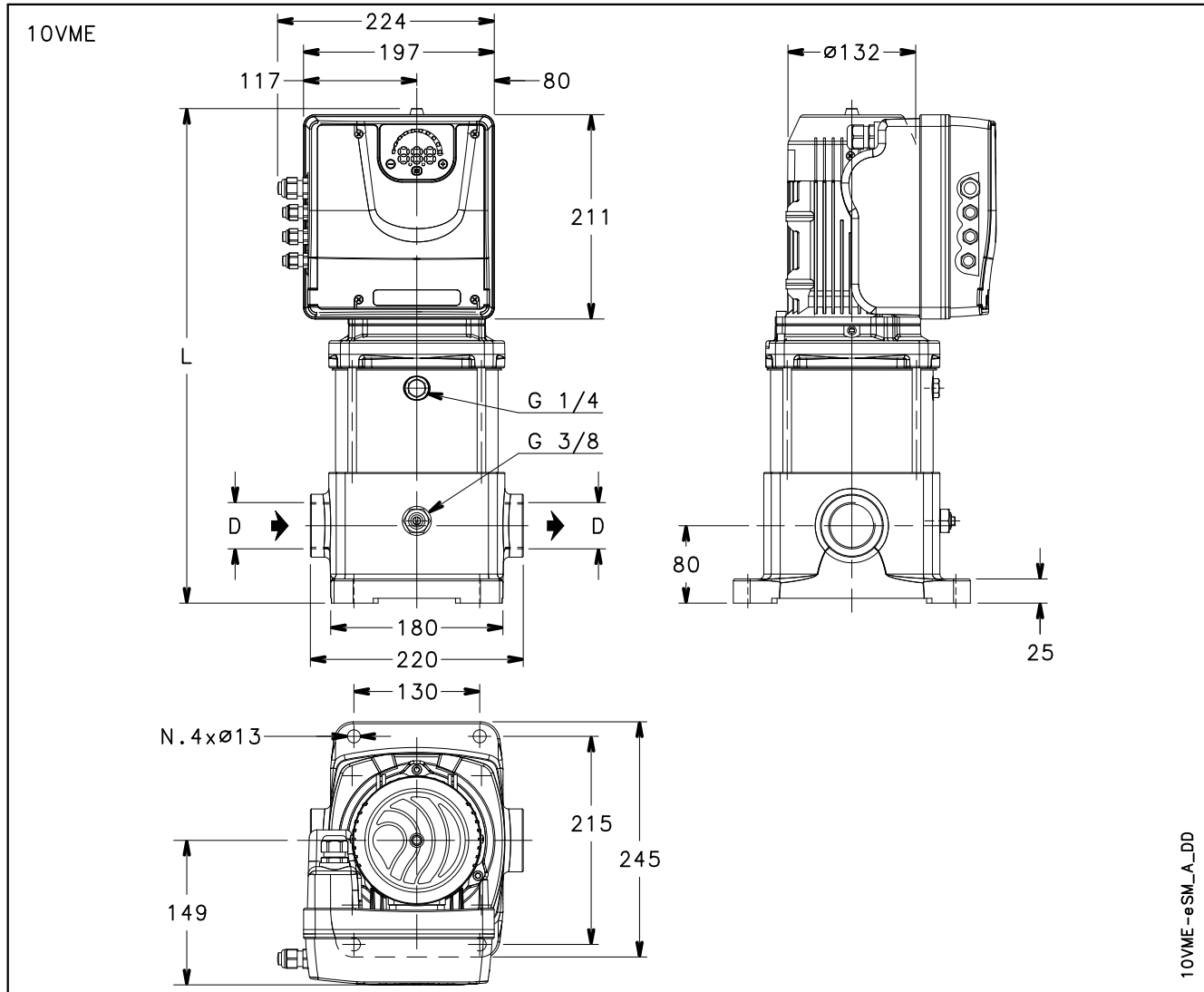

| PUMP TYPE | VERSION | MOTOR | | DIMENSIONS (mm) | | PN bar | WEIGHT kg |
|---------------|--------------|-------|------|-----------------|-----|--------|-----------|
| | | kw | SIZE | D | L | | |
| 10VME01P07M02 | SINGLE-PHASE | 0,75 | 80 | Rp 1 1/2 | 479 | 10 | 19,9 |
| 10VME02P11M02 | | 1,1 | 80 | Rp 1 1/2 | 479 | 10 | 21,5 |
| | | | | | | | |

10vme-esm-2p50-en_a_td

10VME SERIES - THREE-PHASE VERSION DIMENSIONS AND WEIGHTS

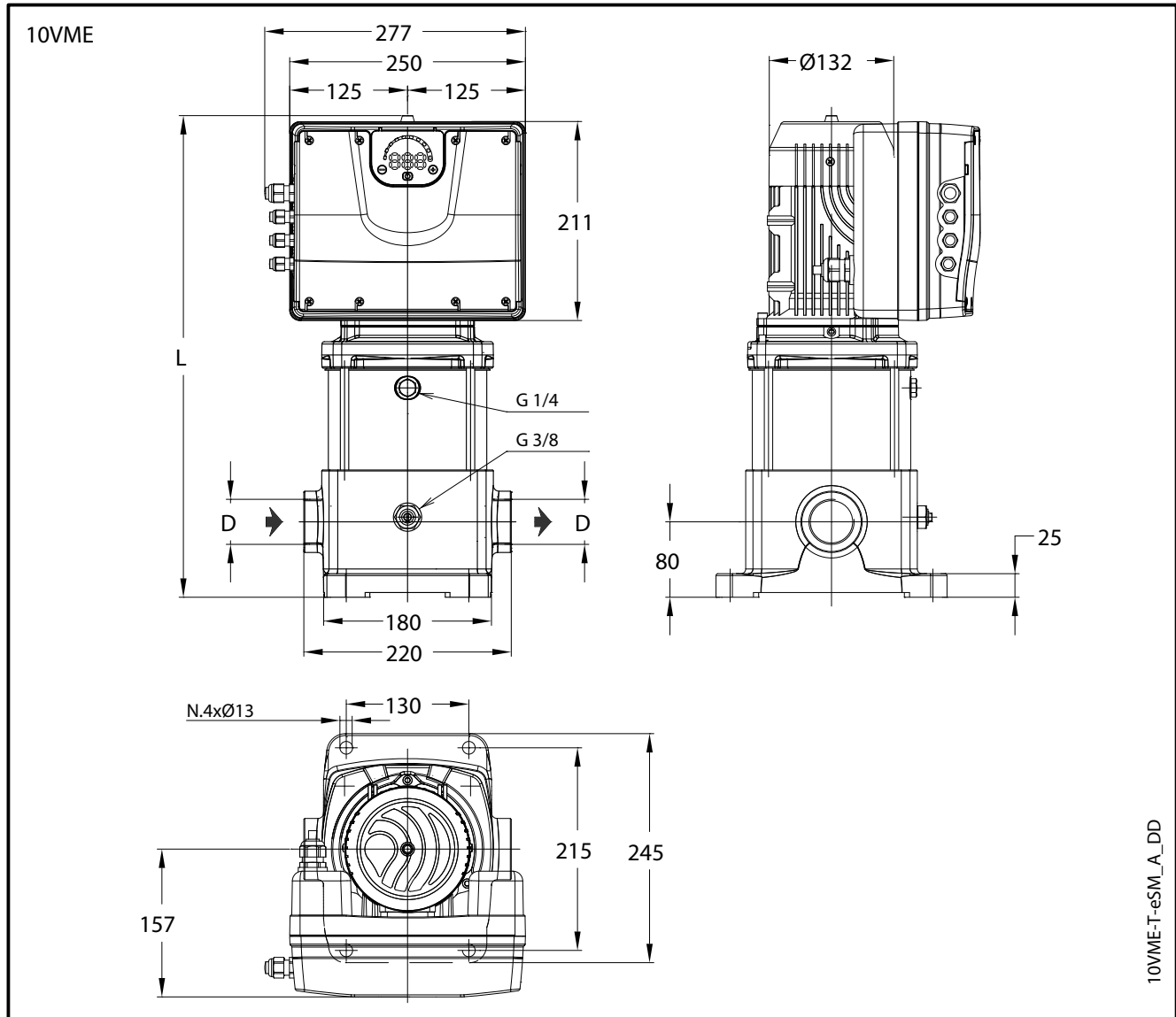

10VME-T-eSM_A_DD

| PUMP TYPE | VERSION | MOTOR | | DIMENSIONS (mm) | | PN bar | WEIGHT kg | |
|---------------|-------------|-------|------|-----------------|-----|--------|-----------|--|
| | | kw | SIZE | D | L | | | |
| 10VME01P07T.. | THREE-PHASE | 0,75 | 80 | Rp 1 1/2 | 479 | 10 | 25,3 | |
| 10VME02P11T.. | | 1,1 | 80 | Rp 1 1/2 | 479 | 10 | 27 | |
| | | | | | | | | |
| | | | | | | | | |

10vme-esm-2p50T-en_a_td

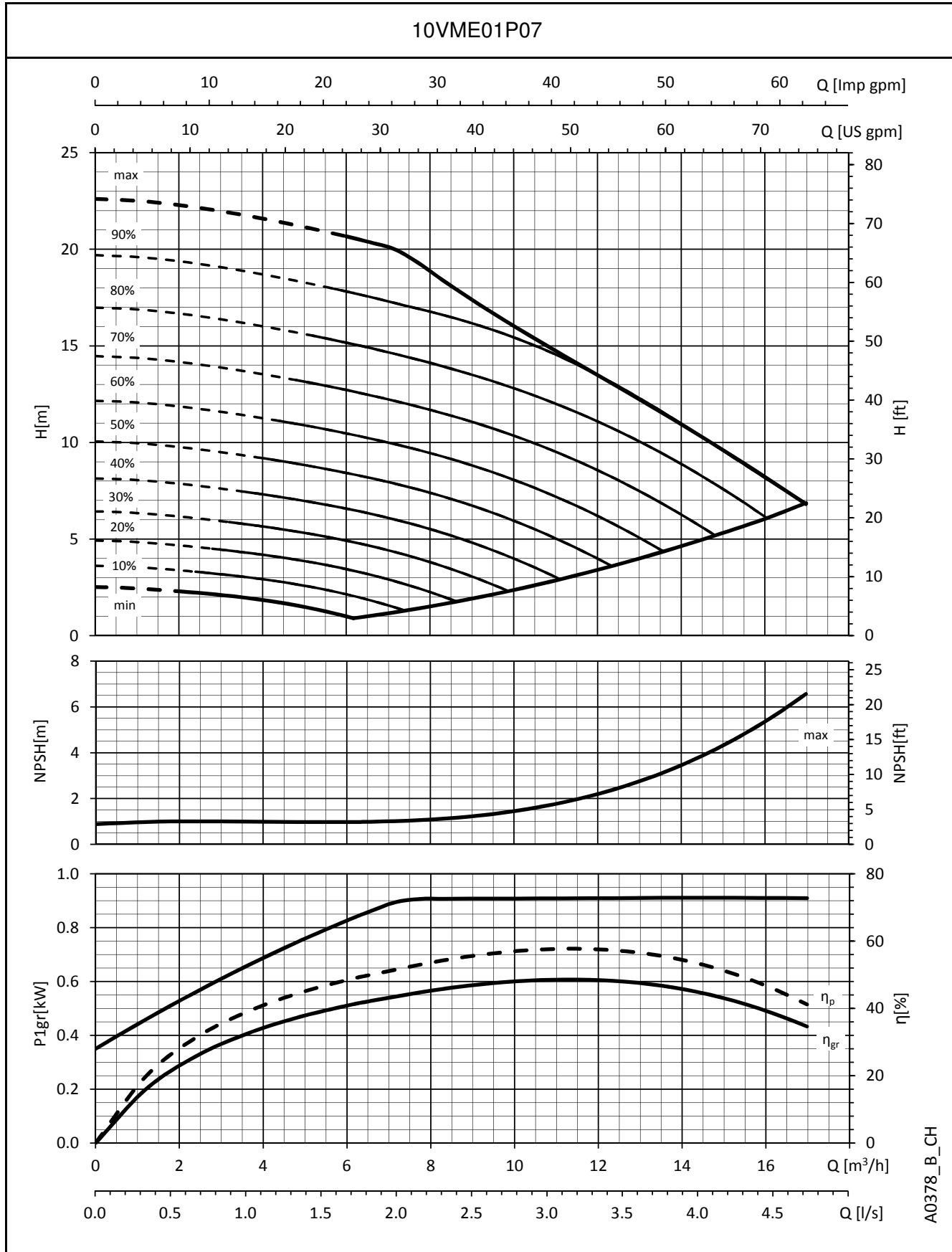
**10VME SERIES
OPERATING CHARACTERISTICS**

A0378_B_CH

 The performances are valid for liquid with density $\rho = 1 \text{ Kg/dm}^3$ and kinematic viscosity $\nu = 1 \text{ mm}^2/\text{sec}$.

**10VME SERIES
OPERATING CHARACTERISTICS**

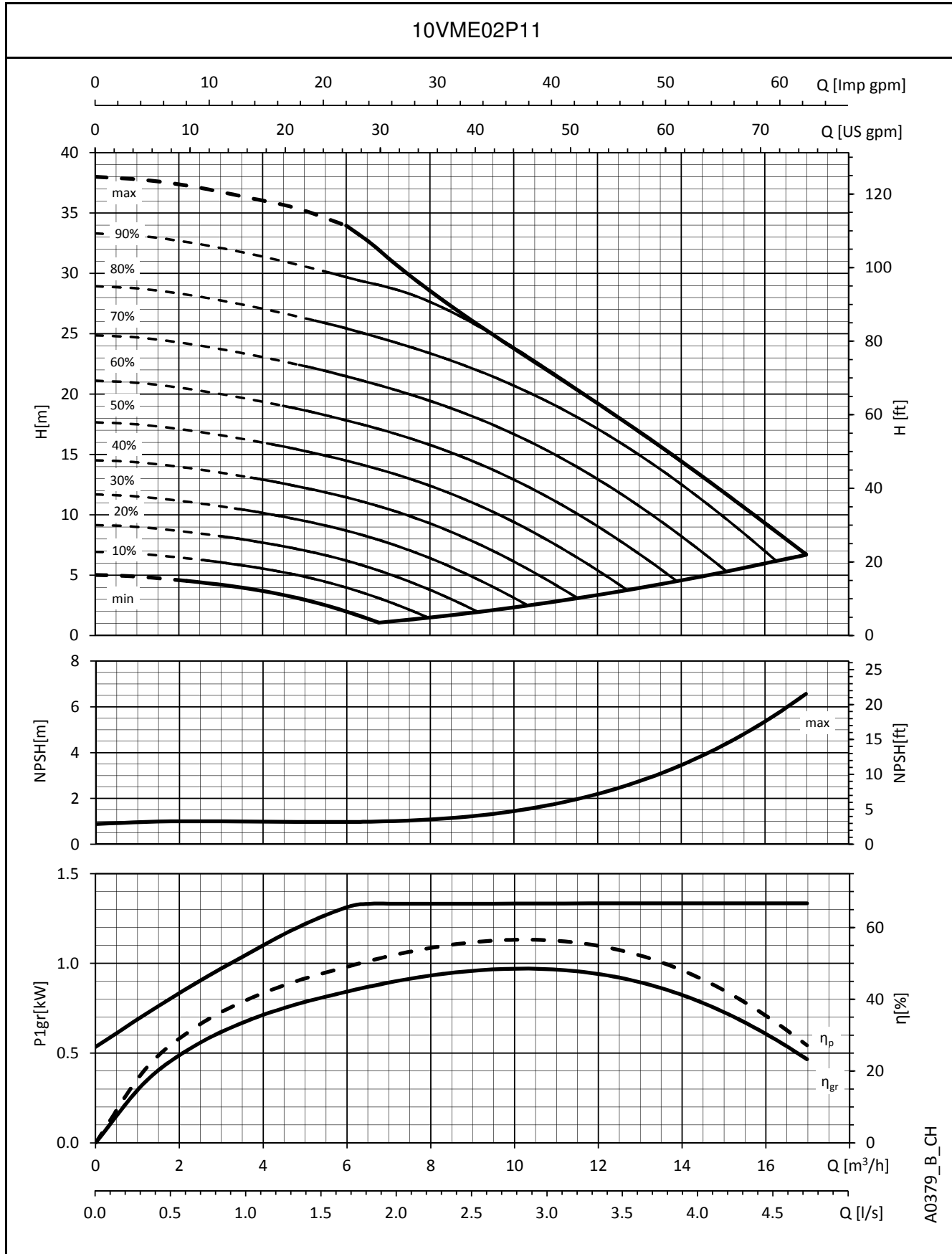

The performances are valid for liquid with density $\rho = 1 \text{ Kg/dm}^3$ and kinematic viscosity $\nu = 1 \text{ mm}^2/\text{sec}$.

REPORTS AND DECLARATIONS

REPORTS AND DECLARATIONS

i) Test reports

- a) **Factory Test Report** (Lowara identity code: 1A)
(not available for all pump types; contact Customer Service in advance)
- Test report compiled at the end of the assembly line, including flow-head performance test (ISO 9906:2012 – Grade 3B) and tightness test.
- b) **Audit Test Report** (Lowara identity code: 1B)
- Test report for electric pumps compiled in the test room, comprising flow-head-pump input-pump efficiency performance test (ISO 9906:2012 – Grade 3B)
- c) **NPSH Test Report** (Lowara identity code: 1B / CTF-NP)
(unavailable for submerged or submersible pumps)
- Test report for electric pumps compiled in the test room, comprising flow-NPSH performance test (ISO 9906:2012 – Grade 3B)
- d) **Noise Test Report** (Lowara identity code: 1B / CTF-RM)
(unavailable for submerged pumps)
- Report indicating sound pressure and power measurements (EN ISO 20361, EN ISO 11203, EN ISO 4871) using the
• intensimetric (EN ISO 9614-1, EN ISO 9614-2), or
• phonometric method.
- e) **Vibration Test Report**
(unavailable for submerged or submersible pumps)
- Report indicating vibration measurements (ISO 10816-1)

ii) Declaration of product conformity with the technical requirements indicated in the order

- a) **EN 10204:2004 - type 2.1** (Lowara identity code: CTF-21)
- does not include test results on supplied or similar products.
- b) **EN 10204:2004 - type 2.2** (Lowara identity code: CTF-22)
- includes test results (materials certificates) on similar products.

iii) Issue of a further EC Declaration of Conformity,

- in addition to the one accompanying the product, it comprises references to European law and the main technical standards (e.g.: MD 2006/42/EC, EMC 2014/30/EU, ErP 2009/125/EC).

N.B.: if the request is made after receipt of the product, communicate the code (name) and serial number (date + progressive number).

iv) Manufacturer's declaration of conformity

- relative to one of more types of products without indicating specific codes and serial numbers.

v) Other certificates and/or documentation on request

- subject to availability or feasibility.

vi) Duplication of certificates and/or documentation on request

- subject to availability or feasibility.

TECHNICAL APPENDIX

NPSH

The minimum operating values that can be reached at the pump suction end are limited by the onset of cavitation.

Cavitation is the formation of vapour-filled cavities within liquids where the pressure is locally reduced to a critical value, or where the local pressure is equal to, or just below the vapour pressure of the liquid.

The vapour-filled cavities flow with the current and when they reach a higher pressure area the vapour contained in the cavities condenses. The cavities collide, generating pressure waves that are transmitted to the walls. These, being subjected to stress cycles, gradually become deformed and yield due to fatigue. This phenomenon, characterized by a metallic noise produced by the hammering on the pipe walls, is called incipient cavitation.

The damage caused by cavitation may be magnified by electrochemical corrosion and a local rise in temperature due to the plastic deformation of the walls. The materials that offer the highest resistance to heat and corrosion are alloy steels, especially austenitic steel. The conditions that trigger cavitation may be assessed by calculating the total net suction head, referred to in technical literature with the acronym NPSH (Net Positive Suction Head).

The NPSH represents the total energy (expressed in m.) of the liquid measured at suction under conditions of incipient cavitation, excluding the vapour pressure (expressed in m.) that the liquid has at the pump inlet.

To find the static height h_z at which to install the machine under safe conditions, the following formula must be verified:

$$h_p + h_z \geq (NPSH_r + 0.5) + h_f + h_{pv} \quad \textcircled{1}$$

where:

h_p is the absolute pressure applied to the free liquid surface in the suction tank, expressed in m. of liquid; h_p is the quotient between the barometric pressure and the specific weight of the liquid.

h_z is the suction lift between the pump axis and the free liquid surface in the suction tank, expressed in m.; h_z is negative when the liquid level is lower than the pump axis.

h_f is the flow resistance in the suction line and its accessories, such as: fittings, foot valve, gate valve, elbows, etc.

h_{pv} is the vapour pressure of the liquid at the operating temperature, expressed in m. of liquid. h_{pv} is the quotient between the P_v vapour pressure and the liquid's specific weight.

0,5 is the safety factor.

The maximum possible suction head for installation depends on the value of the atmospheric pressure (i.e. the elevation above sea level at which the pump is installed) and the temperature of the liquid.

To help the user, with reference to water temperature (4° C) and to the elevation above sea level, the following tables show the drop in hydraulic pressure head in relation to the elevation above sea level, and the suction loss in relation to temperature.

| Water temperature (°C) | 20 | 40 | 60 | 80 | 90 | 110 | 120 |
|------------------------|-----|-----|-----|-----|-----|------|------|
| Suction loss (m) | 0,2 | 0,7 | 2,0 | 5,0 | 7,4 | 15,4 | 21,5 |

| Elevation above sea level (m) | 500 | 1000 | 1500 | 2000 | 2500 | 3000 |
|-------------------------------|------|------|------|------|------|------|
| Suction loss (m) | 0,55 | 1,1 | 1,65 | 2,2 | 2,75 | 3,3 |

Friction loss is shown in the tables of this catalogue. To reduce it to a minimum, especially in cases of high suction head (over 4-5 m.) or within the operating limits with high flow rates, we recommend using a suction line having a larger diameter than that of the pump's suction port. It is always a good idea to position the pump as close as possible to the liquid to be pumped.

Make the following calculation:

Liquid: water at ~15°C $\gamma = 1 \text{ kg/dm}^3$

Flow rate required: 25 m³/h

Head for required delivery: 70 m.

Suction lift: 3,5 m.

The selection is an 33SV3G075T pump whose NPSH required value is, at 25 m³/h, of 2 m.

For water at 15 °C

$$h_p = P_a / \gamma = 10,33\text{m}, h_{pv} = P_v / \gamma = 0,174\text{m} (0,01701 \text{ bar})$$

The H_f flow resistance in the suction line with foot valves is ~ 1,2 m.

By substituting the parameters in formula $\textcircled{1}$ with the numeric values above, we have:

$$10,33 + (-3,5) \geq (2 + 0,5) + 1,2 + 0,17$$

from which we have: 6,8 > 3,9

The relation is therefore verified.

VAPOUR PRESSURE VAPOUR PRESSURE ps AND ρ DENSITY OF WATER TABLE

| t °C | T K | ps bar | ρ kg/dm ³ | t °C | T K | ps bar | ρ kg/dm ³ | t °C | T K | ps bar | ρ kg/dm ³ |
|---------|--------|-----------|------------------------------|---------|--------|-----------|------------------------------|---------|--------|-----------|------------------------------|
| 0 | 273,15 | 0,00611 | 0,9998 | 55 | 328,15 | 0,15741 | 0,9857 | 120 | 393,15 | 1,9854 | 0,9429 |
| 1 | 274,15 | 0,00657 | 0,9999 | 56 | 329,15 | 0,16511 | 0,9852 | 122 | 395,15 | 2,1145 | 0,9412 |
| 2 | 275,15 | 0,00706 | 0,9999 | 57 | 330,15 | 0,17313 | 0,9846 | 124 | 397,15 | 2,2504 | 0,9396 |
| 3 | 276,15 | 0,00758 | 0,9999 | 58 | 331,15 | 0,18147 | 0,9842 | 126 | 399,15 | 2,3933 | 0,9379 |
| 4 | 277,15 | 0,00813 | 1,0000 | 59 | 332,15 | 0,19016 | 0,9837 | 128 | 401,15 | 2,5435 | 0,9362 |
| 5 | 278,15 | 0,00872 | 1,0000 | 60 | 333,15 | 0,1992 | 0,9832 | 130 | 403,15 | 2,7013 | 0,9346 |
| 6 | 279,15 | 0,00935 | 1,0000 | 61 | 334,15 | 0,2086 | 0,9826 | 132 | 405,15 | 2,867 | 0,9328 |
| 7 | 280,15 | 0,01001 | 0,9999 | 62 | 335,15 | 0,2184 | 0,9821 | 134 | 407,15 | 3,041 | 0,9311 |
| 8 | 281,15 | 0,01072 | 0,9999 | 63 | 336,15 | 0,2286 | 0,9816 | 136 | 409,15 | 3,223 | 0,9294 |
| 9 | 282,15 | 0,01147 | 0,9998 | 64 | 337,15 | 0,2391 | 0,9811 | 138 | 411,15 | 3,414 | 0,9276 |
| 10 | 283,15 | 0,01227 | 0,9997 | 65 | 338,15 | 0,2501 | 0,9805 | 140 | 413,15 | 3,614 | 0,9258 |
| 11 | 284,15 | 0,01312 | 0,9997 | 66 | 339,15 | 0,2615 | 0,9799 | 145 | 418,15 | 4,155 | 0,9214 |
| 12 | 285,15 | 0,01401 | 0,9996 | 67 | 340,15 | 0,2733 | 0,9793 | 155 | 428,15 | 5,433 | 0,9121 |
| 13 | 286,15 | 0,01497 | 0,9994 | 68 | 341,15 | 0,2856 | 0,9788 | 160 | 433,15 | 6,181 | 0,9073 |
| 14 | 287,15 | 0,01597 | 0,9993 | 69 | 342,15 | 0,2984 | 0,9782 | 165 | 438,15 | 7,008 | 0,9024 |
| 15 | 288,15 | 0,01704 | 0,9992 | 70 | 343,15 | 0,3116 | 0,9777 | 170 | 443,15 | 7,920 | 0,8973 |
| 16 | 289,15 | 0,01817 | 0,9990 | 71 | 344,15 | 0,3253 | 0,9770 | 175 | 448,15 | 8,924 | 0,8921 |
| 17 | 290,15 | 0,01936 | 0,9988 | 72 | 345,15 | 0,3396 | 0,9765 | 180 | 453,15 | 10,027 | 0,8869 |
| 18 | 291,15 | 0,02062 | 0,9987 | 73 | 346,15 | 0,3543 | 0,9760 | 185 | 458,15 | 11,233 | 0,8815 |
| 19 | 292,15 | 0,02196 | 0,9985 | 74 | 347,15 | 0,3696 | 0,9753 | 190 | 463,15 | 12,551 | 0,8760 |
| 20 | 293,15 | 0,02337 | 0,9983 | 75 | 348,15 | 0,3855 | 0,9748 | 195 | 468,15 | 13,987 | 0,8704 |
| 21 | 294,15 | 0,24850 | 0,9981 | 76 | 349,15 | 0,4019 | 0,9741 | 200 | 473,15 | 15,550 | 0,8647 |
| 22 | 295,15 | 0,02642 | 0,9978 | 77 | 350,15 | 0,4189 | 0,9735 | 205 | 478,15 | 17,243 | 0,8588 |
| 23 | 296,15 | 0,02808 | 0,9976 | 78 | 351,15 | 0,4365 | 0,9729 | 210 | 483,15 | 19,077 | 0,8528 |
| 24 | 297,15 | 0,02982 | 0,9974 | 79 | 352,15 | 0,4547 | 0,9723 | 215 | 488,15 | 21,060 | 0,8467 |
| 25 | 298,15 | 0,03166 | 0,9971 | 80 | 353,15 | 0,4736 | 0,9716 | 220 | 493,15 | 23,198 | 0,8403 |
| 26 | 299,15 | 0,03360 | 0,9968 | 81 | 354,15 | 0,4931 | 0,9710 | 225 | 498,15 | 25,501 | 0,8339 |
| 27 | 300,15 | 0,03564 | 0,9966 | 82 | 355,15 | 0,5133 | 0,9704 | 230 | 503,15 | 27,976 | 0,8273 |
| 28 | 301,15 | 0,03778 | 0,9963 | 83 | 356,15 | 0,5342 | 0,9697 | 235 | 508,15 | 30,632 | 0,8205 |
| 29 | 302,15 | 0,04004 | 0,9960 | 84 | 357,15 | 0,5557 | 0,9691 | 240 | 513,15 | 33,478 | 0,8136 |
| 30 | 303,15 | 0,04241 | 0,9957 | 85 | 358,15 | 0,5780 | 0,9684 | 245 | 518,15 | 36,523 | 0,8065 |
| 31 | 304,15 | 0,04491 | 0,9954 | 86 | 359,15 | 0,6011 | 0,9678 | 250 | 523,15 | 39,776 | 0,7992 |
| 32 | 305,15 | 0,04753 | 0,9951 | 87 | 360,15 | 0,6249 | 0,9671 | 255 | 528,15 | 43,246 | 0,7916 |
| 33 | 306,15 | 0,05029 | 0,9947 | 88 | 361,15 | 0,6495 | 0,9665 | 260 | 533,15 | 46,943 | 0,7839 |
| 34 | 307,15 | 0,05318 | 0,9944 | 89 | 362,15 | 0,6749 | 0,9658 | 265 | 538,15 | 50,877 | 0,7759 |
| 35 | 308,15 | 0,05622 | 0,9940 | 90 | 363,15 | 0,7011 | 0,9652 | 270 | 543,15 | 55,058 | 0,7678 |
| 36 | 309,15 | 0,05940 | 0,9937 | 91 | 364,15 | 0,7281 | 0,9644 | 275 | 548,15 | 59,496 | 0,7593 |
| 37 | 310,15 | 0,06274 | 0,9933 | 92 | 365,15 | 0,7561 | 0,9638 | 280 | 553,15 | 64,202 | 0,7505 |
| 38 | 311,15 | 0,06624 | 0,9930 | 93 | 366,15 | 0,7849 | 0,9630 | 285 | 558,15 | 69,186 | 0,7415 |
| 39 | 312,15 | 0,06991 | 0,9927 | 94 | 367,15 | 0,8146 | 0,9624 | 290 | 563,15 | 74,461 | 0,7321 |
| 40 | 313,15 | 0,07375 | 0,9923 | 95 | 368,15 | 0,8453 | 0,9616 | 295 | 568,15 | 80,037 | 0,7223 |
| 41 | 314,15 | 0,07777 | 0,9919 | 96 | 369,15 | 0,8769 | 0,9610 | 300 | 573,15 | 85,927 | 0,7122 |
| 42 | 315,15 | 0,08198 | 0,9915 | 97 | 370,15 | 0,9094 | 0,9602 | 305 | 578,15 | 92,144 | 0,7017 |
| 43 | 316,15 | 0,09639 | 0,9911 | 98 | 371,15 | 0,9430 | 0,9596 | 310 | 583,15 | 98,70 | 0,6906 |
| 44 | 317,15 | 0,09100 | 0,9907 | 99 | 372,15 | 0,9776 | 0,9586 | 315 | 588,15 | 105,61 | 0,6791 |
| 45 | 318,15 | 0,09582 | 0,9902 | 100 | 373,15 | 1,0133 | 0,9581 | 320 | 593,15 | 112,89 | 0,6669 |
| 46 | 319,15 | 0,10086 | 0,9898 | 102 | 375,15 | 1,0878 | 0,9567 | 325 | 598,15 | 120,56 | 0,6541 |
| 47 | 320,15 | 0,10612 | 0,9894 | 104 | 377,15 | 1,1668 | 0,9552 | 330 | 603,15 | 128,63 | 0,6404 |
| 48 | 321,15 | 0,11162 | 0,9889 | 106 | 379,15 | 1,2504 | 0,9537 | 340 | 613,15 | 146,05 | 0,6102 |
| 49 | 322,15 | 0,11736 | 0,9884 | 108 | 381,15 | 1,3390 | 0,9522 | 350 | 623,15 | 165,35 | 0,5743 |
| 50 | 323,15 | 0,12335 | 0,9880 | 110 | 383,15 | 1,4327 | 0,9507 | 360 | 633,15 | 186,75 | 0,5275 |
| 51 | 324,15 | 0,12961 | 0,9876 | 112 | 385,15 | 1,5316 | 0,9491 | 370 | 643,15 | 210,54 | 0,4518 |
| 52 | 325,15 | 0,13613 | 0,9871 | 114 | 387,15 | 1,6362 | 0,9476 | 374,15 | 647,30 | 221,20 | 0,3154 |
| 53 | 326,15 | 0,14293 | 0,9862 | 116 | 389,15 | 1,7465 | 0,9460 | | | | |
| 54 | 327,15 | 0,15002 | 0,9862 | 118 | 391,15 | 1,8628 | 0,9445 | | | | |

G-at_npsb_b_sc

TABLE OF FLOW RESISTANCE IN 100 m OF STRAIGHT CAST IRON PIPELINE (HAZEN-WILLIAMS FORMULA C=100)

| FLOW RATE | | NOMINAL DIAMETER in mm and inches | | | | | | | | | | | | | | | | | | |
|-------------------|-------|-----------------------------------|------|-------|------|--------|--------|------|--------|------|------|-----|-----|-----|-----|-----|-----|-----|-----|--|
| m ³ /h | l/min | | 15 | 20 | 25 | 32 | 40 | 50 | 65 | 80 | 100 | 125 | 150 | 175 | 200 | 250 | 300 | 350 | 400 | |
| | | | 1/2" | 3/4" | 1" | 1 1/4" | 1 1/2" | 2 | 2 1/2" | 3" | 4" | 5" | 6" | 7" | 8" | 10" | 12" | 14" | 16" | |
| 0,6 | 10 | v | 0,94 | 0,53 | 0,34 | 0,21 | 0,13 | | | | | | | | | | | | | |
| | | hr | 16 | 3,94 | 1,33 | 0,40 | 0,13 | | | | | | | | | | | | | |
| 0,9 | 15 | v | 1,42 | 0,80 | 0,51 | 0,31 | 0,20 | | | | | | | | | | | | | |
| | | hr | 33,9 | 8,35 | 2,82 | 0,85 | 0,29 | | | | | | | | | | | | | |
| 1,2 | 20 | v | 1,89 | 1,06 | 0,68 | 0,41 | 0,27 | 0,17 | | | | | | | | | | | | |
| | | hr | 57,7 | 14,21 | 4,79 | 1,44 | 0,49 | 0,16 | | | | | | | | | | | | |
| 1,5 | 25 | v | 2,36 | 1,33 | 0,85 | 0,52 | 0,33 | 0,21 | | | | | | | | | | | | |
| | | hr | 87,2 | 21,5 | 7,24 | 2,18 | 0,73 | 0,25 | | | | | | | | | | | | |
| 1,8 | 30 | v | 2,83 | 1,59 | 1,02 | 0,62 | 0,40 | 0,25 | | | | | | | | | | | | |
| | | hr | 122 | 30,1 | 10,1 | 3,05 | 1,03 | 0,35 | | | | | | | | | | | | |
| 2,1 | 35 | v | 3,30 | 1,86 | 1,19 | 0,73 | 0,46 | 0,30 | | | | | | | | | | | | |
| | | hr | 162 | 40,0 | 13,5 | 4,06 | 1,37 | 0,46 | | | | | | | | | | | | |
| 2,4 | 40 | v | | 2,12 | 1,36 | 0,83 | 0,53 | 0,34 | 0,20 | | | | | | | | | | | |
| | | hr | | 51,2 | 17,3 | 5,19 | 1,75 | 0,59 | 0,16 | | | | | | | | | | | |
| 3 | 50 | v | | 2,65 | 1,70 | 1,04 | 0,66 | 0,42 | 0,25 | | | | | | | | | | | |
| | | hr | | 77,4 | 26,1 | 7,85 | 2,65 | 0,89 | 0,25 | | | | | | | | | | | |
| 3,6 | 60 | v | | 3,18 | 2,04 | 1,24 | 0,80 | 0,51 | 0,30 | | | | | | | | | | | |
| | | hr | | 108 | 36,6 | 11,0 | 3,71 | 1,25 | 0,35 | | | | | | | | | | | |
| 4,2 | 70 | v | | 3,72 | 2,38 | 1,45 | 0,93 | 0,59 | 0,35 | | | | | | | | | | | |
| | | hr | | 144 | 48,7 | 14,6 | 4,93 | 1,66 | 0,46 | | | | | | | | | | | |
| 4,8 | 80 | v | | 4,25 | 2,72 | 1,66 | 1,06 | 0,68 | 0,40 | | | | | | | | | | | |
| | | hr | | 185 | 62,3 | 18,7 | 6,32 | 2,13 | 0,59 | | | | | | | | | | | |
| 5,4 | 90 | v | | | 3,06 | 1,87 | 1,19 | 0,76 | 0,45 | 0,30 | | | | | | | | | | |
| | | hr | | | 77,5 | 23,3 | 7,85 | 2,65 | 0,74 | 0,27 | | | | | | | | | | |
| 6 | 100 | v | | | 3,40 | 2,07 | 1,33 | 0,85 | 0,50 | 0,33 | | | | | | | | | | |
| | | hr | | | 94,1 | 28,3 | 9,54 | 3,22 | 0,90 | 0,33 | | | | | | | | | | |
| 7,5 | 125 | v | | | 4,25 | 2,59 | 1,66 | 1,06 | 0,63 | 0,41 | | | | | | | | | | |
| | | hr | | | 142 | 42,8 | 14,4 | 4,86 | 1,36 | 0,49 | | | | | | | | | | |
| 9 | 150 | v | | | 3,11 | 1,99 | 1,27 | 0,75 | 0,50 | 0,32 | | | | | | | | | | |
| | | hr | | | 59,9 | 20,2 | 6,82 | 1,90 | 0,69 | 0,23 | | | | | | | | | | |
| 10,5 | 175 | v | | | 3,63 | 2,32 | 1,49 | 0,88 | 0,58 | 0,37 | | | | | | | | | | |
| | | hr | | | 79,7 | 26,9 | 9,07 | 2,53 | 0,92 | 0,31 | | | | | | | | | | |
| 12 | 200 | v | | | 4,15 | 2,65 | 1,70 | 1,01 | 0,66 | 0,42 | | | | | | | | | | |
| | | hr | | | 102 | 34,4 | 11,6 | 3,23 | 1,18 | 0,40 | | | | | | | | | | |
| 15 | 250 | v | | | 5,18 | 3,32 | 2,12 | 1,26 | 0,83 | 0,53 | 0,34 | | | | | | | | | |
| | | hr | | | 154 | 52,0 | 17,5 | 4,89 | 1,78 | 0,60 | 0,20 | | | | | | | | | |
| 18 | 300 | v | | | 3,98 | 2,55 | 1,51 | 1,00 | 0,64 | 0,41 | | | | | | | | | | |
| | | hr | | | 72,8 | 24,6 | 6,85 | 2,49 | 0,84 | 0,28 | | | | | | | | | | |
| 24 | 400 | v | | | 5,31 | 3,40 | 2,01 | 1,33 | 0,85 | 0,54 | 0,38 | | | | | | | | | |
| | | hr | | | 124 | 41,8 | 11,66 | 4,24 | 1,43 | 0,48 | 0,20 | | | | | | | | | |
| 30 | 500 | v | | | 6,63 | 4,25 | 2,51 | 1,66 | 1,06 | 0,68 | 0,47 | | | | | | | | | |
| | | hr | | | 187 | 63,2 | 17,6 | 6,41 | 2,16 | 0,73 | 0,30 | | | | | | | | | |
| 36 | 600 | v | | | 5,10 | 3,02 | 1,99 | 1,27 | 0,82 | 0,57 | 0,42 | | | | | | | | | |
| | | hr | | | 88,6 | 24,7 | 8,98 | 3,03 | 1,02 | 0,42 | 0,20 | | | | | | | | | |
| 42 | 700 | v | | | 5,94 | 3,52 | 2,32 | 1,49 | 0,95 | 0,66 | 0,49 | | | | | | | | | |
| | | hr | | | 118 | 32,8 | 11,9 | 4,03 | 1,36 | 0,56 | 0,26 | | | | | | | | | |
| 48 | 800 | v | | | 6,79 | 4,02 | 2,65 | 1,70 | 1,09 | 0,75 | 0,55 | | | | | | | | | |
| | | hr | | | 151 | 42,0 | 15,3 | 5,16 | 1,74 | 0,72 | 0,34 | | | | | | | | | |
| 54 | 900 | v | | | 7,64 | 4,52 | 2,99 | 1,91 | 1,22 | 0,85 | 0,62 | | | | | | | | | |
| | | hr | | | 188 | 52,3 | 19,0 | 6,41 | 2,16 | 0,89 | 0,42 | | | | | | | | | |
| 60 | 1000 | v | | | 5,03 | 3,32 | 2,12 | 1,36 | 0,94 | 0,69 | 0,53 | | | | | | | | | |
| | | hr | | | 63,5 | 23,1 | 7,79 | 2,63 | 1,08 | 0,51 | 0,27 | | | | | | | | | |
| 75 | 1250 | v | | | 6,28 | 4,15 | 2,65 | 1,70 | 1,18 | 0,87 | 0,66 | | | | | | | | | |
| | | hr | | | 96,0 | 34,9 | 11,8 | 3,97 | 1,63 | 0,77 | 0,40 | | | | | | | | | |
| 90 | 1500 | v | | | 7,54 | 4,98 | 3,18 | 2,04 | 1,42 | 1,04 | 0,80 | | | | | | | | | |
| | | hr | | | 134 | 48,9 | 16,5 | 5,57 | 2,29 | 1,08 | 0,56 | | | | | | | | | |
| 105 | 1750 | v | | | 8,79 | 5,81 | 3,72 | 2,38 | 1,65 | 1,21 | 0,93 | | | | | | | | | |
| | | hr | | | 179 | 65,1 | 21,9 | 7,40 | 3,05 | 1,44 | 0,75 | | | | | | | | | |
| 120 | 2000 | v | | | 6,63 | 4,25 | 2,72 | 1,89 | 1,39 | 1,06 | 0,68 | | | | | | | | | |
| | | hr | | | 83,3 | 28,1 | 9,48 | 3,90 | 1,84 | 0,96 | 0,32 | | | | | | | | | |
| 150 | 2500 | v | | | 8,29 | 5,31 | 3,40 | 2,36 | 1,73 | 1,33 | 0,85 | | | | | | | | | |
| | | hr | | | 126 | 42,5 | 14,3 | 5,89 | 2,78 | 1,45 | 0,49 | | | | | | | | | |
| 180 | 3000 | v | | | 6,37 | 4,08 | 2,83 | 2,08 | 1,59 | 1,02 | 0,71 | | | | | | | | | |
| | | hr | | | 59,5 | 20,1 | 8,26 | 3,90 | 2,03 | 0,69 | 0,28 | | | | | | | | | |
| 210 | 3500 | v | | | 7,43 | 4,76 | 3,30 | 2,43 | 1,86 | 1,19 | 0,83 | | | | | | | | | |
| | | hr | | | 79,1 | 26,7 | 11,0 | 5,18 | 2,71 | 0,91 | 0,38 | | | | | | | | | |
| 240 | 4000 | v | | | 8,49 | 5,44 | 3,77 | 2,77 | 2,12 | 1,36 | 0,94 | | | | | | | | | |
| | | hr | | | 101 | 34,2 | 14,1 | 6,64 | 3,46 | 1,17 | 0,48 | | | | | | | | | |
| 300 | 5000 | v | | | 6,79 | 4,72 | 3,47 | 2,65 | 1,70 | 1,18 | 0,82 | | | | | | | | | |
| | | hr | | | 51,6 | 21,2 | 10,0 | 5,23 | 1,77 | 0,73 | 0,27 | | | | | | | | | |
| 360 | 6000 | v | | | 8,15 | 5,66 | 4,16 | 3,18 | 2,04 | 1,42 | 1,02 | | | | | | | | | |
| | | hr | | | 72,3 | 29,8 | 14,1 | 7,33 | 2,47 | 1,02 | 0,38 | | | | | | | | | |
| 420 | 7000 | v | | | 6,61 | 4,85 | 3,72 | 2,38 | 1,65 | 1,21 | 0,93 | | | | | | | | | |
| | | hr | | | 39,6 | 18,7 | 9,75 | 3,29 | 1,35 | 0,64 | 0,24 | | | | | | | | | |
| 480 | 8000 | v | | | 7,55 | 5,55 | 4,25 | 2,72 | 1,89 | 1,39 | 1,02 | | | | | | | | | |
| | | hr | | | 50,7 | 23,9 | 12,49 | 4,21 | 1,73 | 0,82 | 0,30 | | | | | | | | | |
| 540 | 9000 | v | | | 8,49 | 6,24 | 4,78 | 3,06 | 2,12 | 1,56 | 1,19 | | | | | | | | | |
| | | hr | | | 63,0 | 29,8 | 15,5 | 5,24 | 2,16 | 1,02 | 0,53 | | | | | | | | | |
| 600 | 10000 | v | | | 6,93 | 5,31 | 3,40 | 2,36 | 1,73 | 1,33 | 0,82 | | | </ | | | | | | |

FLOW RESISTANCE

TABLE OF FLOW RESISTANCE IN BENDS, VALVES AND GATES

The flow resistance is calculated using the equivalent pipeline length method according to the table below:

| ACCESSORY TYPE | DN | | | | | | | | | | | |
|--------------------------------|-----|-----|-----|-----|-----|-----|-----|-----|-----|-----|------|------|
| | 25 | 32 | 40 | 50 | 65 | 80 | 100 | 125 | 150 | 200 | 250 | 300 |
| Equivalent pipeline length (m) | | | | | | | | | | | | |
| 45° bend | 0,2 | 0,2 | 0,4 | 0,4 | 0,6 | 0,6 | 0,9 | 1,1 | 1,5 | 1,9 | 2,4 | 2,8 |
| 90° bend | 0,4 | 0,6 | 0,9 | 1,1 | 1,3 | 1,5 | 2,1 | 2,6 | 3,0 | 3,9 | 4,7 | 5,8 |
| 90° smooth bend | 0,4 | 0,4 | 0,4 | 0,6 | 0,9 | 1,1 | 1,3 | 1,7 | 1,9 | 2,8 | 3,4 | 3,9 |
| Union tee or cross | 1,1 | 1,3 | 1,7 | 2,1 | 2,6 | 3,2 | 4,3 | 5,3 | 6,4 | 7,5 | 10,7 | 12,8 |
| Gate valve | - | - | - | 0,2 | 0,2 | 0,2 | 0,4 | 0,4 | 0,6 | 0,9 | 1,1 | 1,3 |
| Foot check valve | 1,1 | 1,5 | 1,9 | 2,4 | 3,0 | 3,4 | 4,7 | 5,9 | 7,4 | 9,6 | 11,8 | 13,9 |
| Non return valve | 1,1 | 1,5 | 1,9 | 2,4 | 3,0 | 3,4 | 4,7 | 5,9 | 7,4 | 9,6 | 11,8 | 13,9 |

G-a-pcv-en_b_th

The table is valid for the Hazen Williams coefficient $C=100$ (cast iron pipework);

for steel pipework, multiply the values by 1,41;

for stainless steel, copper and coated cast iron pipework, multiply the values by 1,85;

When the **equivalent pipeline length** has been determined, the flow resistance is obtained from the table of flow resistance.

The values given are guideline values which are bound to vary slightly according to the model, especially for gate valves and non-return valves, for which it is a good idea to check the values supplied by manufacturers.

VOLUMETRIC CAPACITY

| Litres per minute l/min | Cubic metres per hour m ³ /h | Cubic feet per hour ft ³ /h | Cubic feet per minute ft ³ /min | Imperial gallon per minute Imp. gal/min | U.S. gallon per minute US gal/min |
|-------------------------------|---|--|--|---|---|
| 1,000 | 0,0600 | 2,1189 | 0,0353 | 0,2200 | 0,2642 |
| 16,6667 | 1,0000 | 35,3147 | 0,5886 | 3,6662 | 4,4029 |
| 0,4719 | 0,0283 | 1,0000 | 0,0167 | 0,1038 | 0,1247 |
| 28,3168 | 1,6990 | 60,0000 | 1,0000 | 6,2288 | 7,4805 |
| 4,5461 | 0,2728 | 9,6326 | 0,1605 | 1,0000 | 1,2009 |
| 3,7854 | 0,2271 | 8,0208 | 0,1337 | 0,8327 | 1,0000 |

PRESSURE AND HEAD

| Newton per square metre N/m ² | kilo Pascal kPa | bar bar | Pound force per square inch psi | Metre of water m H ₂ O | Millimetre of mercury mm Hg |
|--|--------------------|--------------------|---------------------------------------|---|-----------------------------------|
| 1,0000 | 0,0010 | 1×10^{-5} | $1,45 \times 10^{-4}$ | $1,02 \times 10^{-4}$ | 0,0075 |
| 1 000,0000 | 1,0000 | 0,0100 | 0,1450 | 0,1020 | 7,5006 |
| 1×10^5 | 100,0000 | 1,0000 | 14,5038 | 10,1972 | 750,0638 |
| 6 894,7570 | 6,8948 | 0,0689 | 1,0000 | 0,7031 | 51,7151 |
| 9 806,6500 | 9,8067 | 0,0981 | 1,4223 | 1,0000 | 73,5561 |
| 133,3220 | 0,1333 | 0,0013 | 0,0193 | 0,0136 | 1,0000 |

LENGTH

| Millimetre mm | Centimetre cm | Metre m | Inch in | Foot ft | Yard yd |
|------------------|------------------|---------------|---------------|---------------|---------------|
| 1,0000 | 0,1000 | 0,0010 | 0,0394 | 0,0033 | 0,0011 |
| 10,0000 | 1,0000 | 0,0100 | 0,3937 | 0,0328 | 0,0109 |
| 1 000,0000 | 100,0000 | 1,0000 | 39,3701 | 3,2808 | 1,0936 |
| 25,4000 | 2,5400 | 0,0254 | 1,0000 | 0,0833 | 0,0278 |
| 304,8000 | 30,4800 | 0,3048 | 12,0000 | 1,0000 | 0,3333 |
| 914,4000 | 91,4400 | 0,9144 | 36,0000 | 3,0000 | 1,0000 |

VOLUME

| Cubic metre m ³ | Litre L | Millilitre ml | Imperial gallon imp. gal. | U.S. gallon US gal. | Cubic foot ft ³ |
|-------------------------------|---------------|------------------|------------------------------|------------------------|-------------------------------|
| 1,0000 | 1 000,0000 | 1×10^6 | 219,9694 | 264,1720 | 35,3147 |
| 0,0010 | 1,0000 | 1 000,0000 | 0,2200 | 0,2642 | 0,0353 |
| 1×10^{-6} | 0,0010 | 1,0000 | $2,2 \times 10^{-4}$ | $2,642 \times 10^{-4}$ | $3,53 \times 10^{-5}$ |
| 0,0045 | 4,5461 | 4 546,0870 | 1,0000 | 1,2009 | 0,1605 |
| 0,0038 | 3,7854 | 3 785,4120 | 0,8327 | 1,0000 | 0,1337 |
| 0,0283 | 28,3168 | 28 316,8466 | 6,2288 | 7,4805 | 1,0000 |

TEMPERATURE

| Water | Kelvin K | Celsius °C | Fahrenheit °F | $^{\circ}\text{F} = ^{\circ}\text{C} \times \frac{9}{5} + 32$ $^{\circ}\text{C} = (^{\circ}\text{F} - 32) \times \frac{5}{9}$ |
|---------|-------------|---------------|------------------|--|
| icing | 273,1500 | 0,0000 | 32,0000 | |
| boiling | 373,1500 | 100,0000 | 212,0000 | |

G-at_pp-en_b_sc

**FURTHER PRODUCT SELECTION
AND DOCUMENTATION**
Xylect

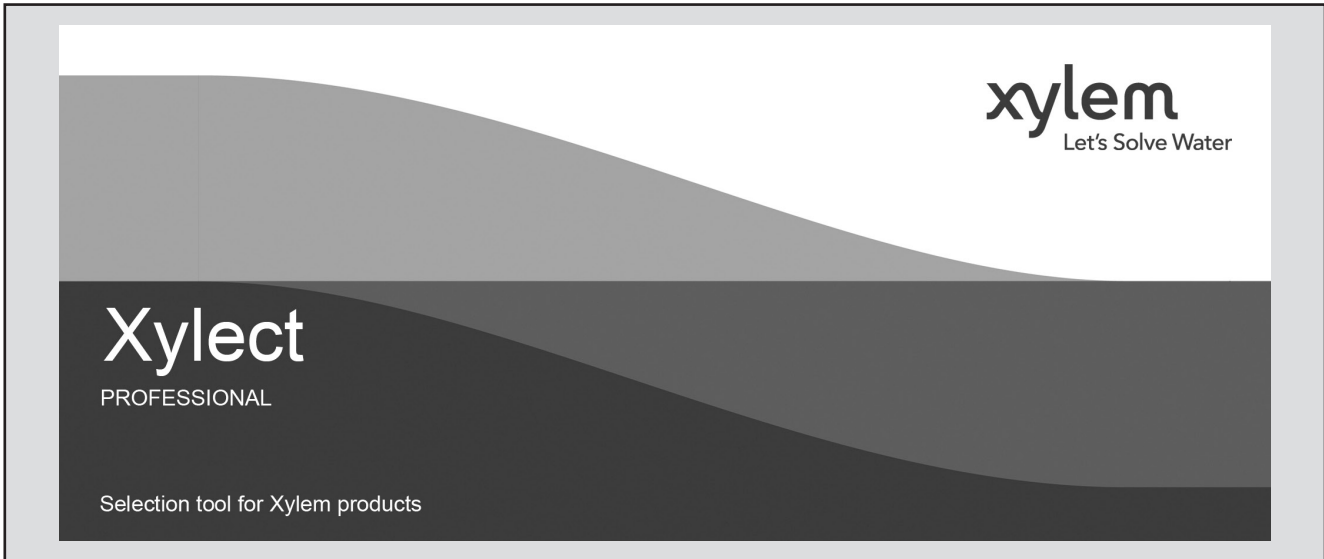

Xylect is pump solution selection software with an extensive online database of product information across the entire Lowara range of pumps and related products, with multiple search options and helpful project management facilities. The system holds up-to-date product information on thousands of products and accessories.

The possibility to search by applications and the detailed information output given makes it easy to make the optimal selection without having detailed knowledge about the Lowara products.

The search can be made by:

- Application
- Product type
- Duty point

Xylect gives a detailed output:

- List with search results
- Performance curves (flow, head, power, efficiency, NPSH)
- Motor data
- Dimensional drawings
- Options
- Data sheet printouts
- Document downloads incl dxf files

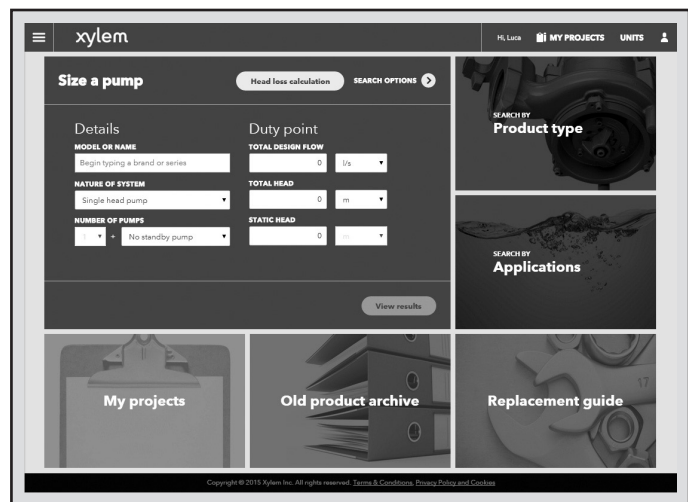

The search by application guides users not familiar with the product range to the right choice.

FURTHER PRODUCT SELECTION AND DOCUMENTATION

Xylect



The detailed output makes it easy to select the optimal pump from the given alternatives.

The best way to work with Xylect is to create a personal account. This makes it possible to:

- Set own standard units
- Create and save projects
- Share projects with other Xylect users

Every registered user has a proper space, where all projects are saved.

For more information about Xylect please contact our sales network or visit www.xylect.com.

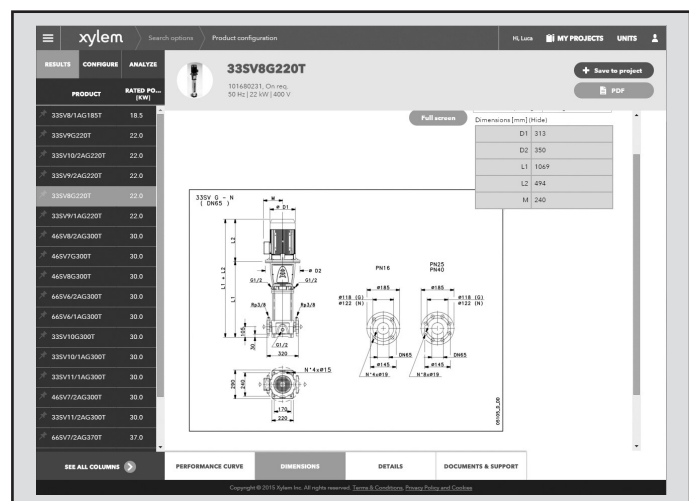

Dimensional drawings appear on the screen and can be downloaded in dxf format.

Xylem |'zīləm|

- 1) The tissue in plants that brings water upward from the roots;
- 2) a leading global water technology company.

We're a global team unified in a common purpose: creating advanced technology solutions to the world's water challenges. Developing new technologies that will improve the way water is used, conserved, and re-used in the future is central to our work. Our products and services move, treat, analyze, monitor and return water to the environment, in public utility, industrial, residential and commercial building services settings. Xylem also provides a leading portfolio of smart metering, network technologies and advanced analytics solutions for water, electric and gas utilities. In more than 150 countries, we have strong, long-standing relationships with customers who know us for our powerful combination of leading product brands and applications expertise with a strong focus on developing comprehensive, sustainable solutions.

For more information on how Xylem can help you, go to www.xylem.com.



For information and technical support
Xylem Service Italia Srl

Via Dottor Vittorio Lombardi 14
36075 - Montecchio Maggiore (VI) - Italy
Tel. (+39) 0444 707111
Fax (+39) 0444 491043
www.xylem.com/lowara

Xylem Service Italia Srl reserves the right to make modification without prior notice.
Lowara, Xylem are trademarks of Xylem Inc. or one of its subsidiaries
© 2024 Xylem, Inc.